

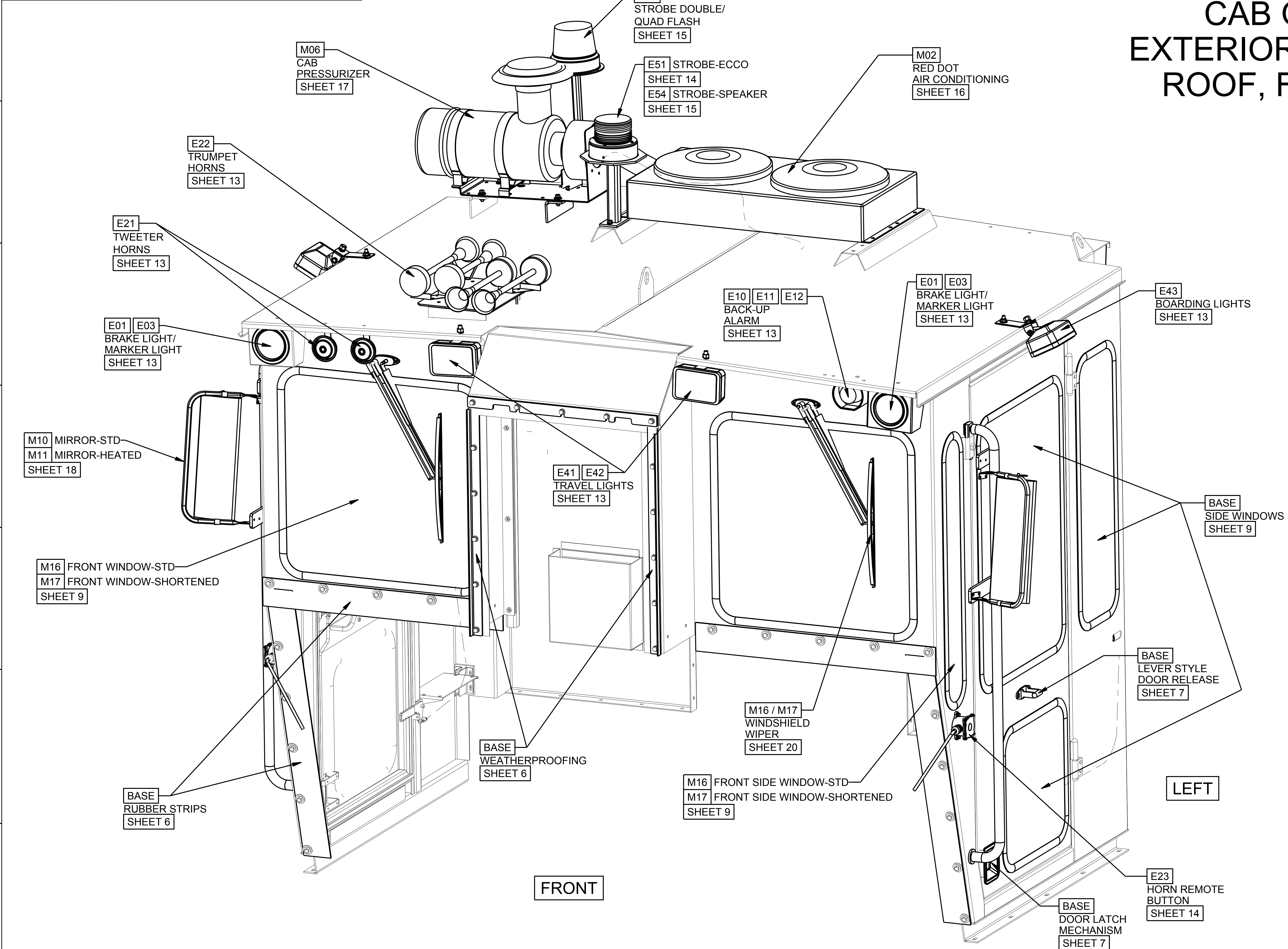

# CAB OVERVIEW: EXTERIOR COMPONENTS ROOF, FRONT & LEFT



FRONT

LEFT

CUSTOMARY: ALL DIMENSIONS IN INCHES				THIRD ANGLE PROJECTION	
IMPLIED TOLERANCES		PRODUCT: MODELS C & CX			
FRACTION	± 1/8	DESCRIPTION: SPECIFICATION, CX-BASED CAB			
X	± .06	SIZE	SCALE	DRAWING CODE NUMBER	REV.
XX	± .03	D	1/8	22224100	-
XXX	± .010	ASSEMBLY:-			
PLANE ANGLES $\neq$ 90°		SHEET 2 OF 21			

REVISION HISTORY  
LOCATED ON LAST SHEET

# CAB OVERVIEW: EXTERIOR COMPONENTS ROOF, REAR & RIGHT

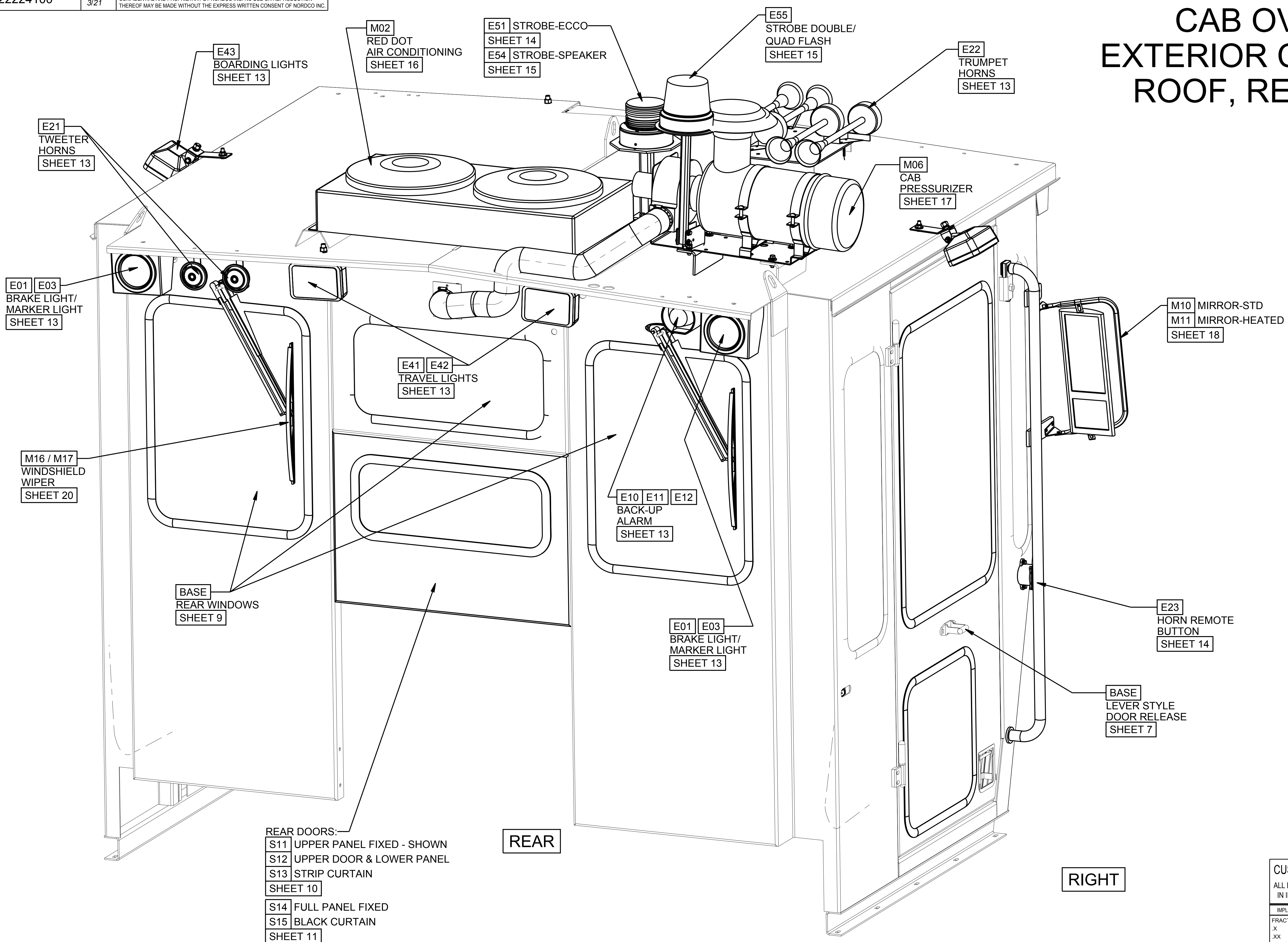

CUSTOMARY: ALL DIMENSIONS IN INCHES					
IMPLIED TOLERANCES		PRODUCT: MODELS C & CX			
FRACTION		DESCRIPTION: SPECIFICATION, CX-BASED CAB			
X	± .06	SIZE	SCALE	DRAWING CODE NUMBER	REV.
XX	± .03	D	1/8	22224100	-
XXX	± .010	ASSEMBLY:-		SHEET 3	OF 21
MACHINE FINISH UNLESS OTHERWISE STATED		PLANE ANGLES 90°-1°			

REVISION HISTORY  
LOCATED ON LAST SHEET

# CAB OVERVIEW: INTERIOR COMPONENTS

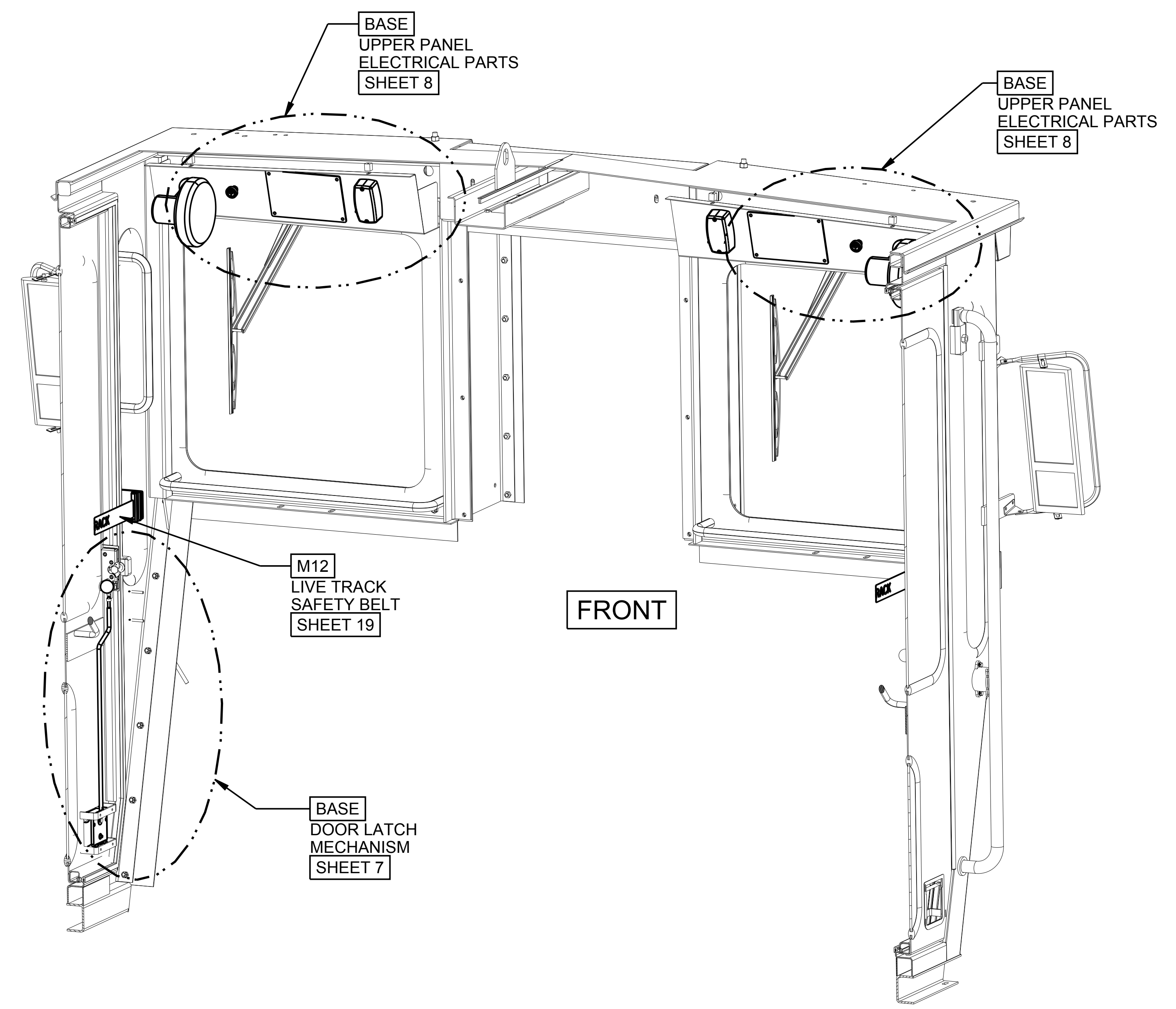
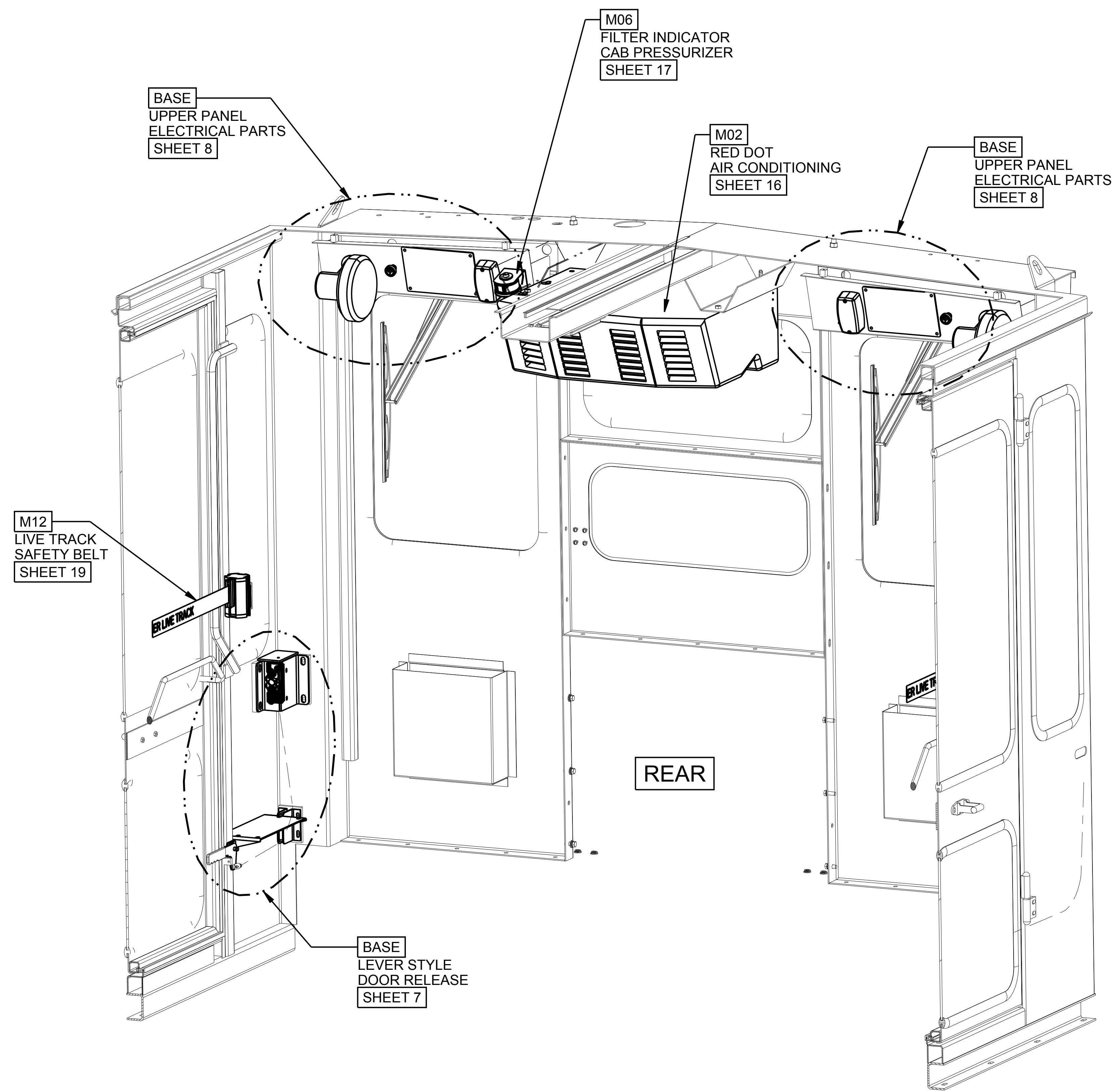

CUSTOMARY:				THIRD ANGLE PROJECTION	
ALL DIMENSIONS IN INCHES		PRODUCT: MODELS C & CX			
IMPLIED TOLERANCES		DESCRIPTION: SPECIFICATION, CX-BASED CAB			
FRACTION	± 1/8	SIZE	SCALE	DRAWING CODE NUMBER	REV.
X	± .06	D	1/8	22224100	-
XX	± .03	ASSEMBLY:-		SHEET 4 OF 21	
XXX	± .010	PLANE ANGLES 90°-1°			

REVISION HISTORY  
LOCATED ON LAST SHEET

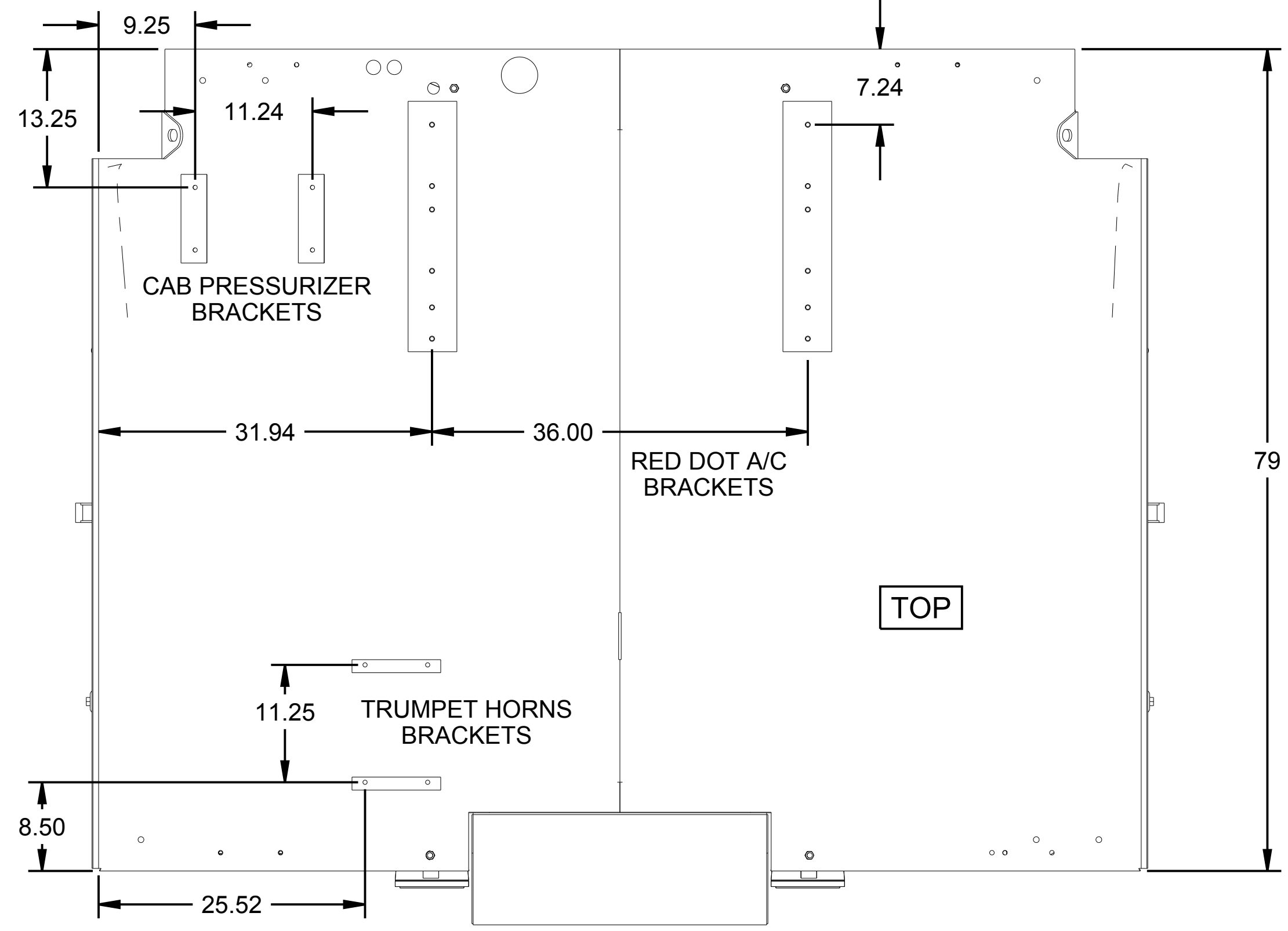

# CAB OVERVIEW: OVERALL DIMENSIONS

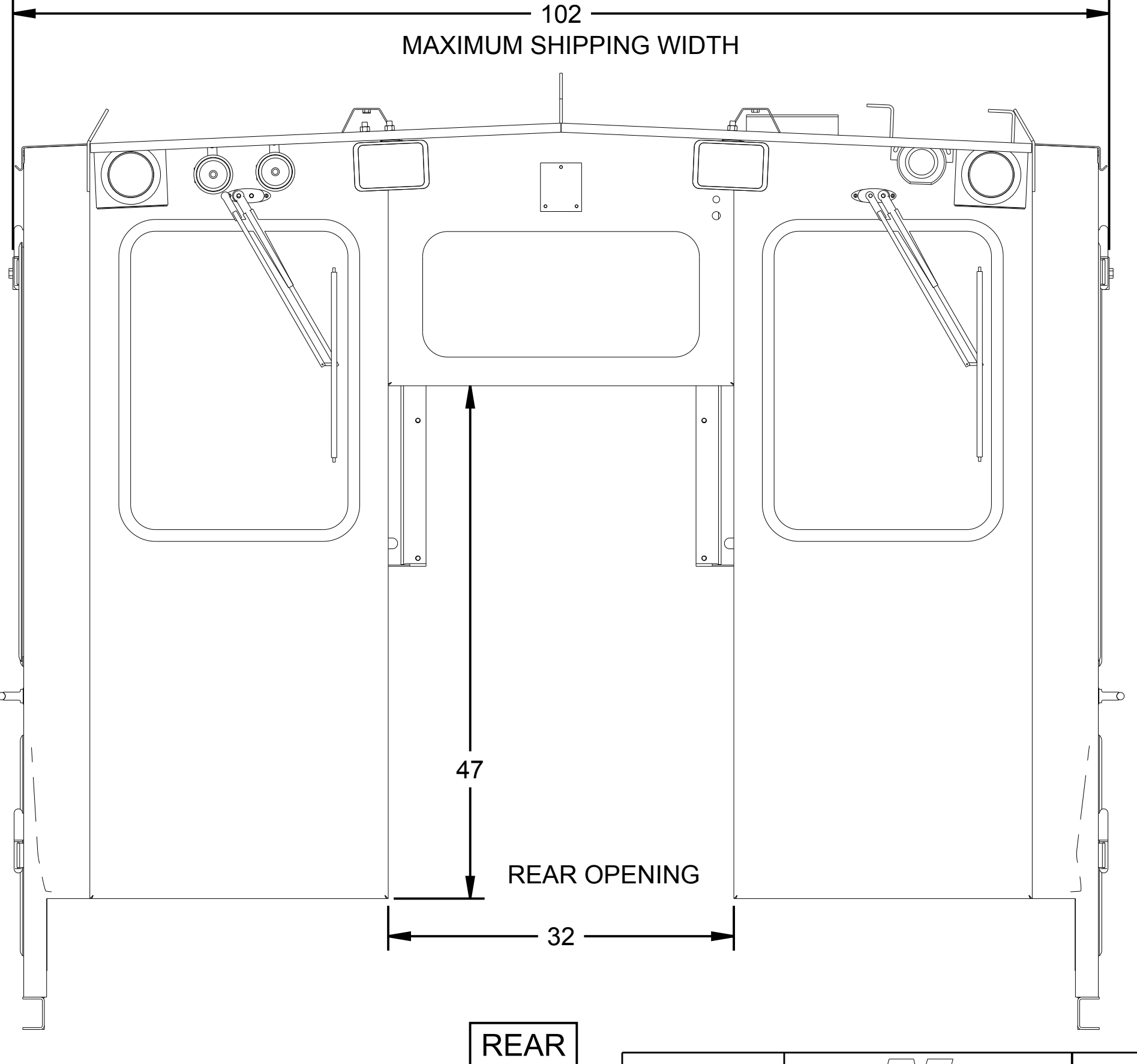
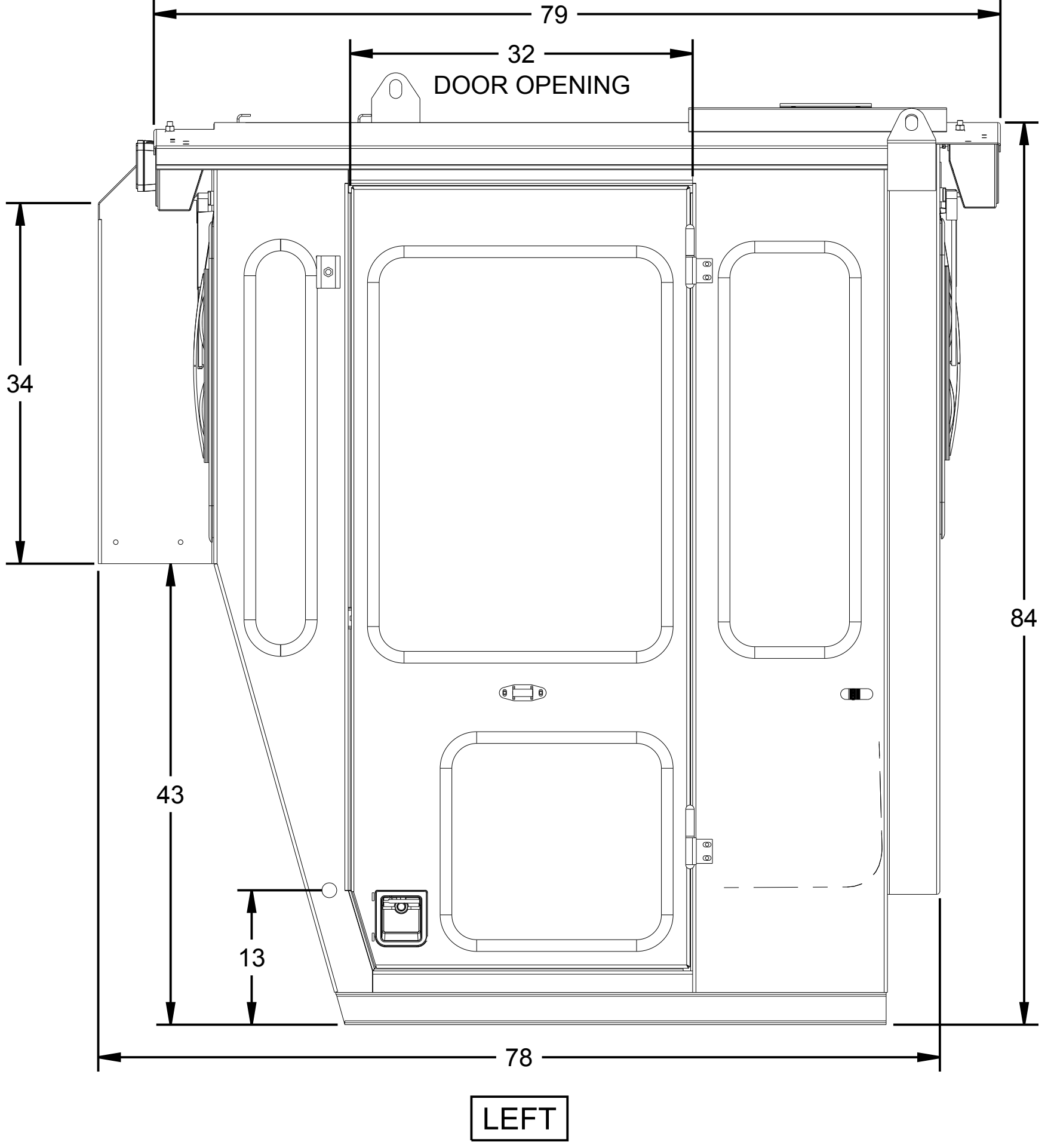
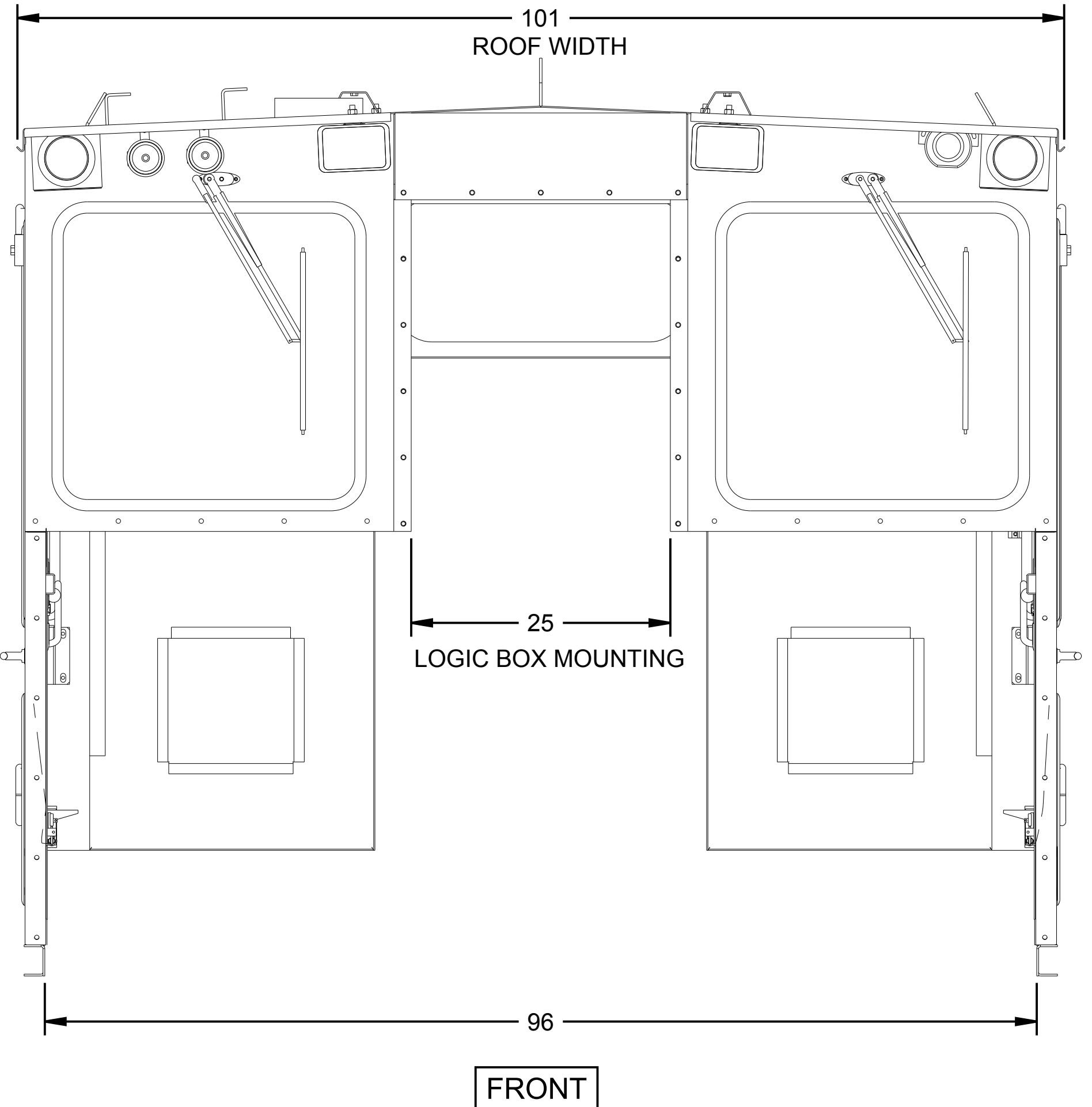
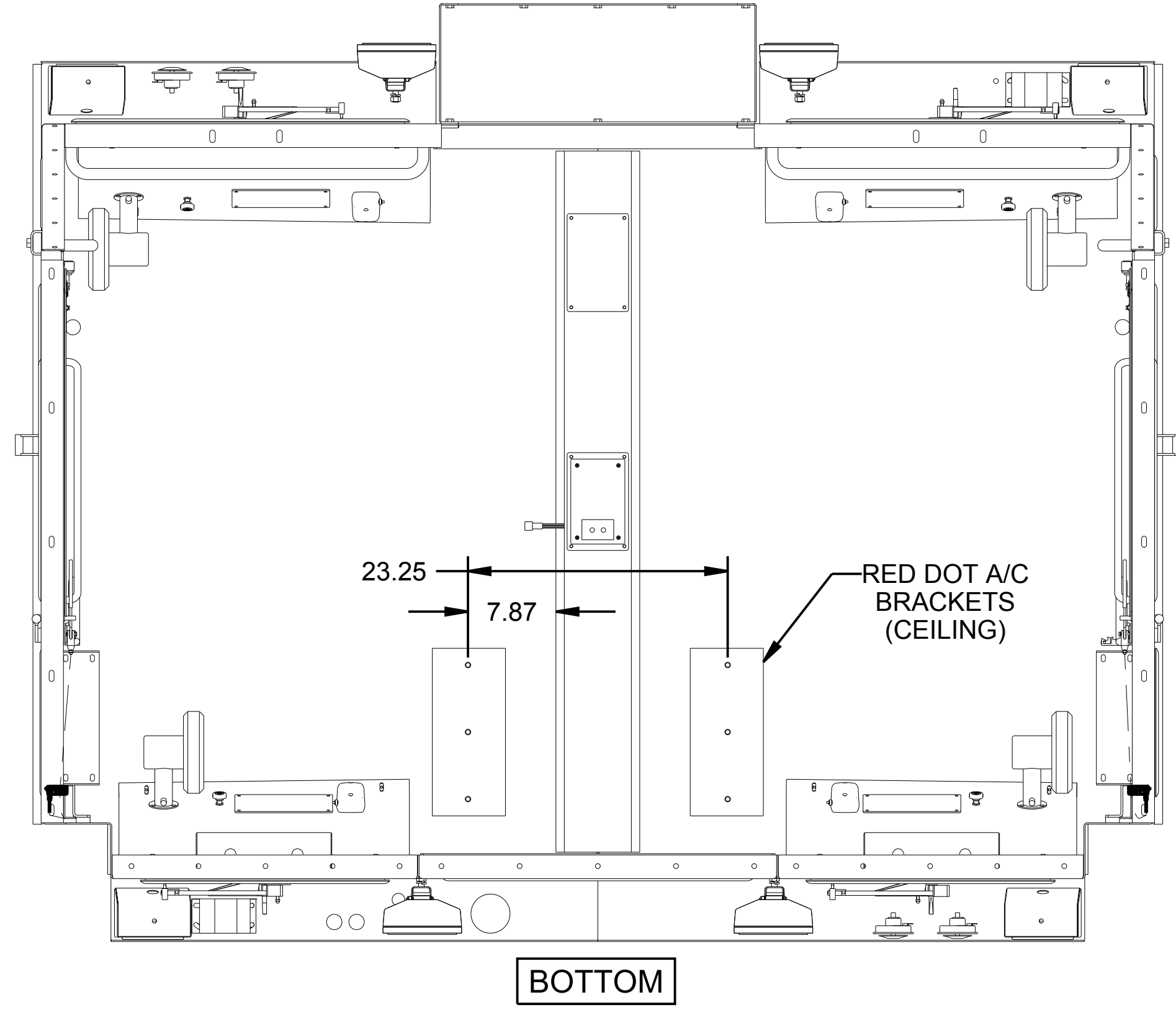

CUSTOMARY:				THIRD ANGLE PROJECTION	
ALL DIMENSIONS IN INCHES		PRODUCT: MODELS C & CX			
IMPLIED TOLERANCES		DESCRIPTION: SPECIFICATION, CX-BASED CAB			
FRACTION	± 1/8	SIZE	SCALE	DRAWING CODE NUMBER	REV.
X	± .06	D	1/8	22224100	-
XX	± .03	ASSEMBLY:-			
XXX	± .010	SHEET 5 OF 21			
MACHINE FINISH UNLESS OTHERWISE STATED					
PLANE ANGLES W/ F°					

REVISION HISTORY LOCATED ON LAST SHEET

BASE CAB			RUBBER STRIPS & WEATHERPROOFING	
ITEM NO.	PART NUMBER OR MATERIAL	QTY. REQ.	PART NAME	NORDCO DWG.
1	76415001	2	STRIP,RUBBER 1/8 X 2.5 X 33.4	Y
2	76415002	1	STRIP,RUBBER 1/8 X 2.5 X 28.0	Y
3	76415003	2	STRIP,RUBBER 1/8 X 4.0 X 42.0	Y
4	76415008	2	STRIP,RUBBER 1/8 X 4.0 X 35.5	Y
5	13710180	1	BAR,CLAMP TOP LOGIC BOX CAB	Y
6	13710181	1	BAR,CLAMP SIDE LH LOGIC BOX CAB	Y
7	13710182	1	BAR,CLAMP SIDE RH LOGIC BOX CAB	Y
8	2774781	37	CAPSCREW, HEX 3/8-16 X 1.0	
9	3057364	22	WASHER,FENDER LARGE 3/8	
10	3060031	22	WASHER,FENDER 3/8	
11	3042020	22	LOCNUT, HEX 3/8-16	
12	3060470	15	WASHER,SAE 3/8	
13	3064470	15	WASHER,LOCK 3/8	

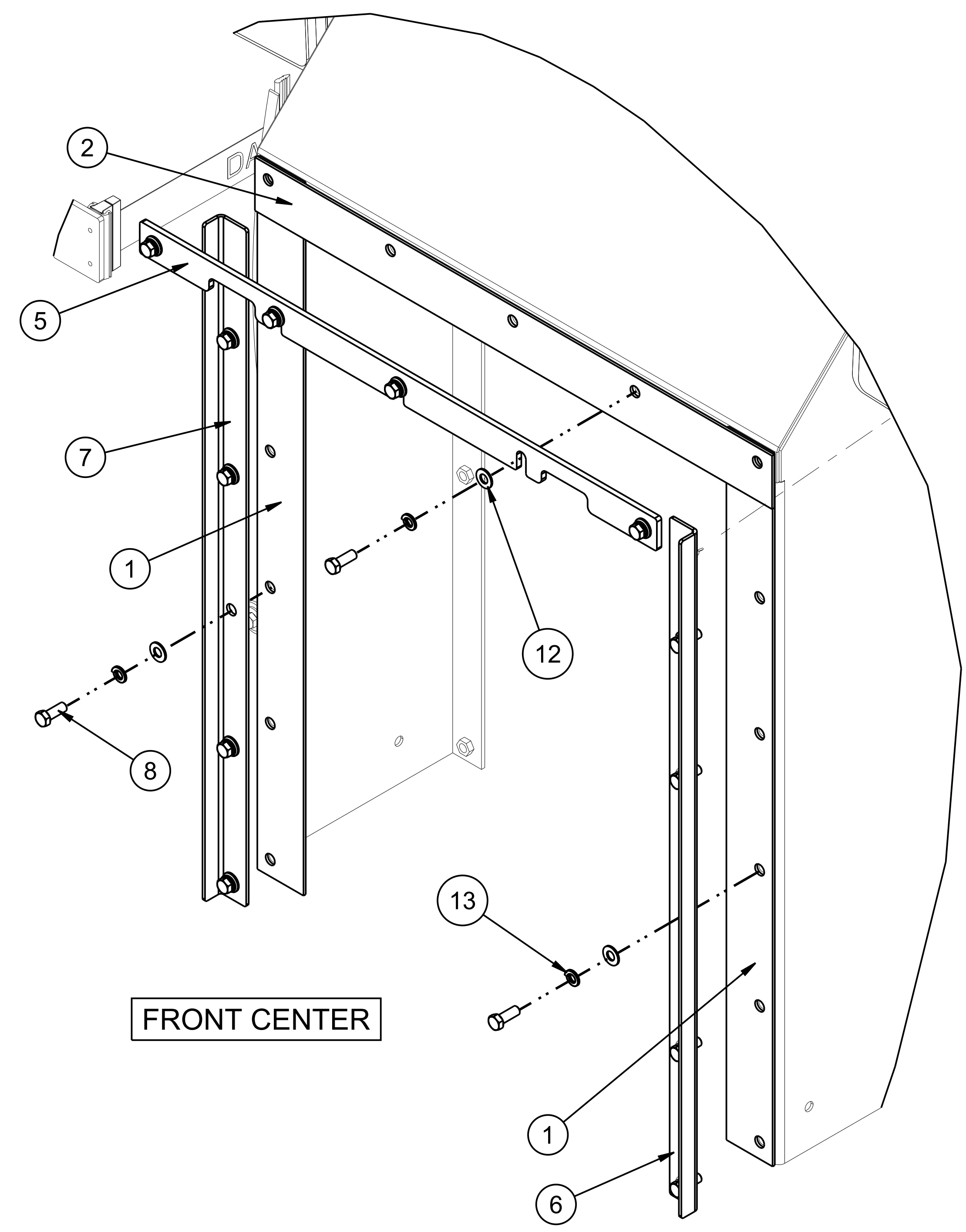
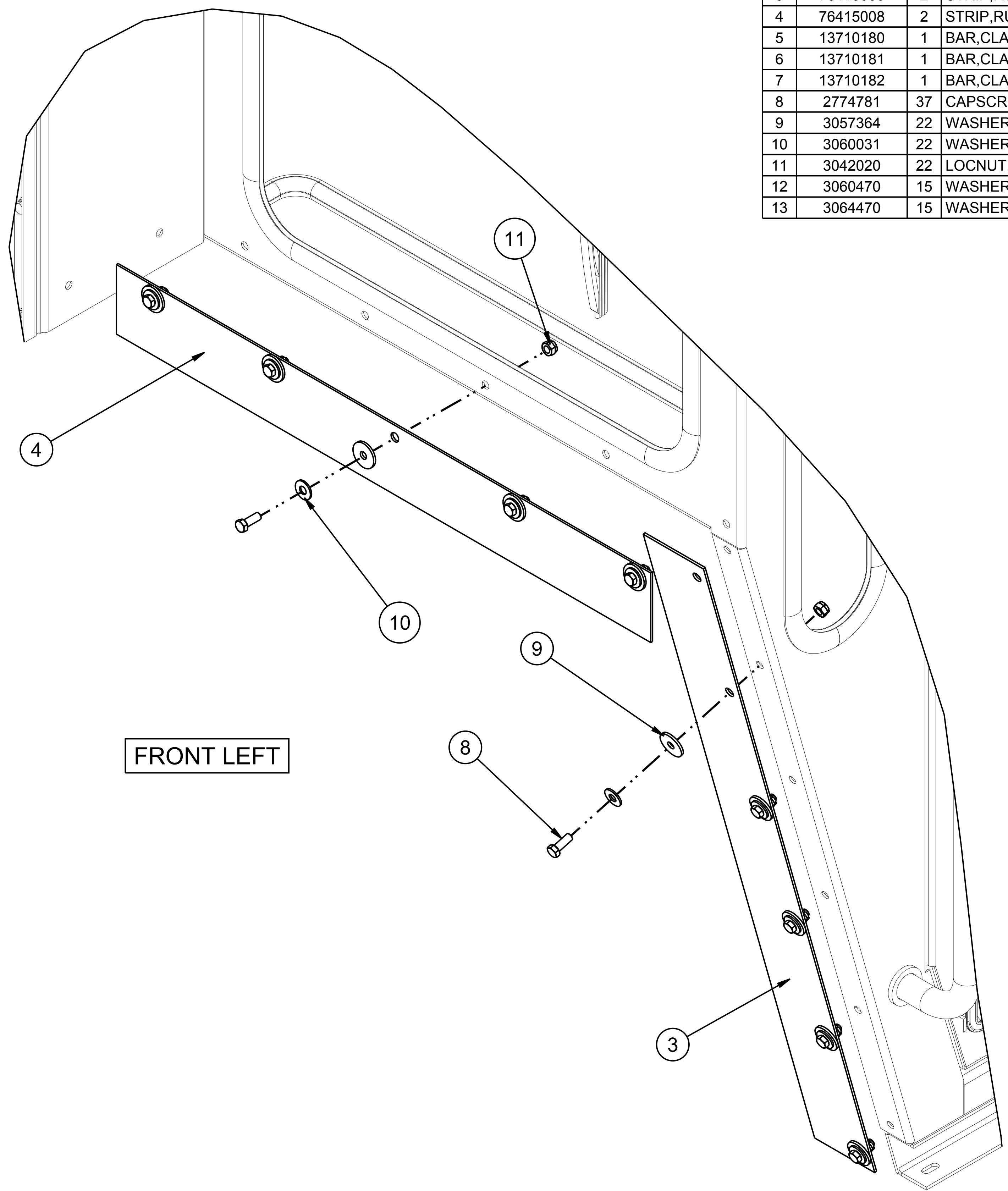

CUSTOMARY: ALL DIMENSIONS IN INCHES				THIRD ANGLE PROJECTION	
IMPLIED TOLERANCES		PRODUCT: MODELS C & CX			
FRACTION	± 1/8	DESCRIPTION: SPECIFICATION, CX-BASED CAB			
X	± .06	SIZE	SCALE	DRAWING CODE NUMBER	REV.
XX	± .03	D	1/8	22224100	-
XXX	± .010	ASSEMBLY:-		SHEET 6	OF 21
MACHINE FINISH UNLESS OTHERWISE STATED PLANE ANGLES 90°-1°					

REVISION HISTORY LOCATED ON LAST SHEET

BASE CAB		DOOR LATCH MECHANISM		
ITEM NO.	PART NUMBER OR MATERIAL	QTY. REQ.	PART NAME	NORDCO DWG.
1	47515770	1	LATCH,DOOR R.H. TWO ROTOR	
2	47515771	1	LATCH,DOOR L.H. TWO ROTOR	
3	22231009	1	HANDLE,RH DOOR PADDLE TYPE	
4	22231003	1	HANDLE,LH DOOR PADDLE TYPE	
5	22231117	2	LINKAGE ARM W/CLEVIS & CLIPS	
6	47170901	2	KNOB,INTERIOR DOOR	

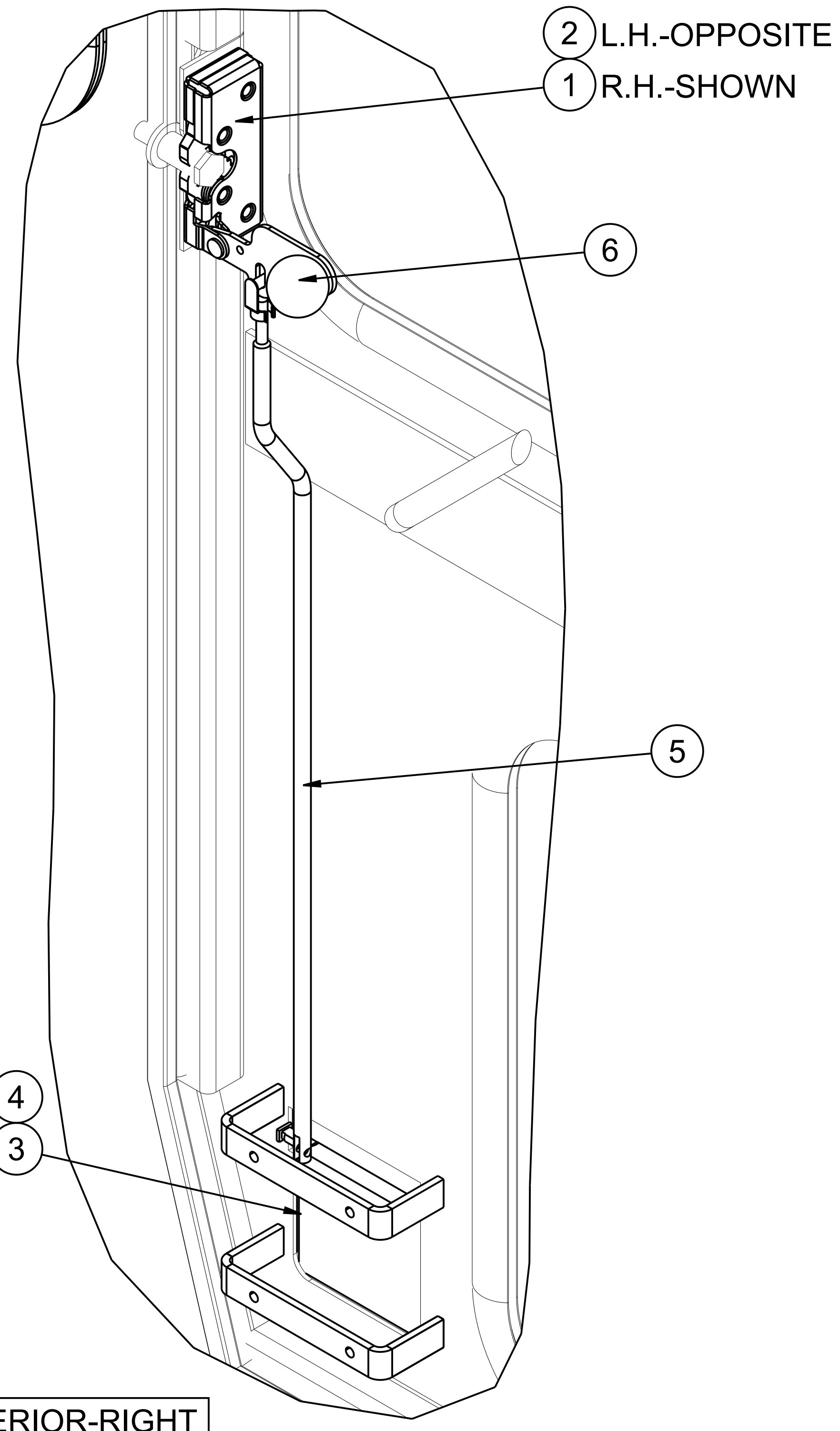

BASE CAB		LEVER STYLE DOOR RELEASE		
ITEM NO.	PART NUMBER OR MATERIAL	QTY. REQ.	PART NAME	NORDCO DWG.
1	21462405	1	BRACKET,R.H. DOOR LATCH	Y
2	21462406	1	BRACKET,L.H. DOOR LATCH	Y
3	21373865	4	FLAT,LATCH SUPPORT	Y
4	21462407	2	BRACKET,GUIDE BLOCK	Y
5	21373866	2	FLAT,GUIDE BLOCK	Y
6	21462409	2	BRACKET,RELEASE HANDLE DOOR	Y
7	42030155	2	HANDLE,RELEASE LEVER DOOR	Y
8	21373869	2	FLAT,RELEASE HANDLE STOP	Y
9	66291155	2	ROPE,WIRE W/CLEVIS ENDS	Y
10	47515770	1	LATCH,DOOR R.H. TWO ROTOR	
11	47515771	1	LATCH,DOOR L.H. TWO ROTOR	
12	4598996	2	GRIP,FLAT VINYL BLACK	
13	21462408	2	BRACKET,LATCH STRIKER	Y
14	56900030	2	PLATE,MOUNTING OPERATOR'S BOX	Y

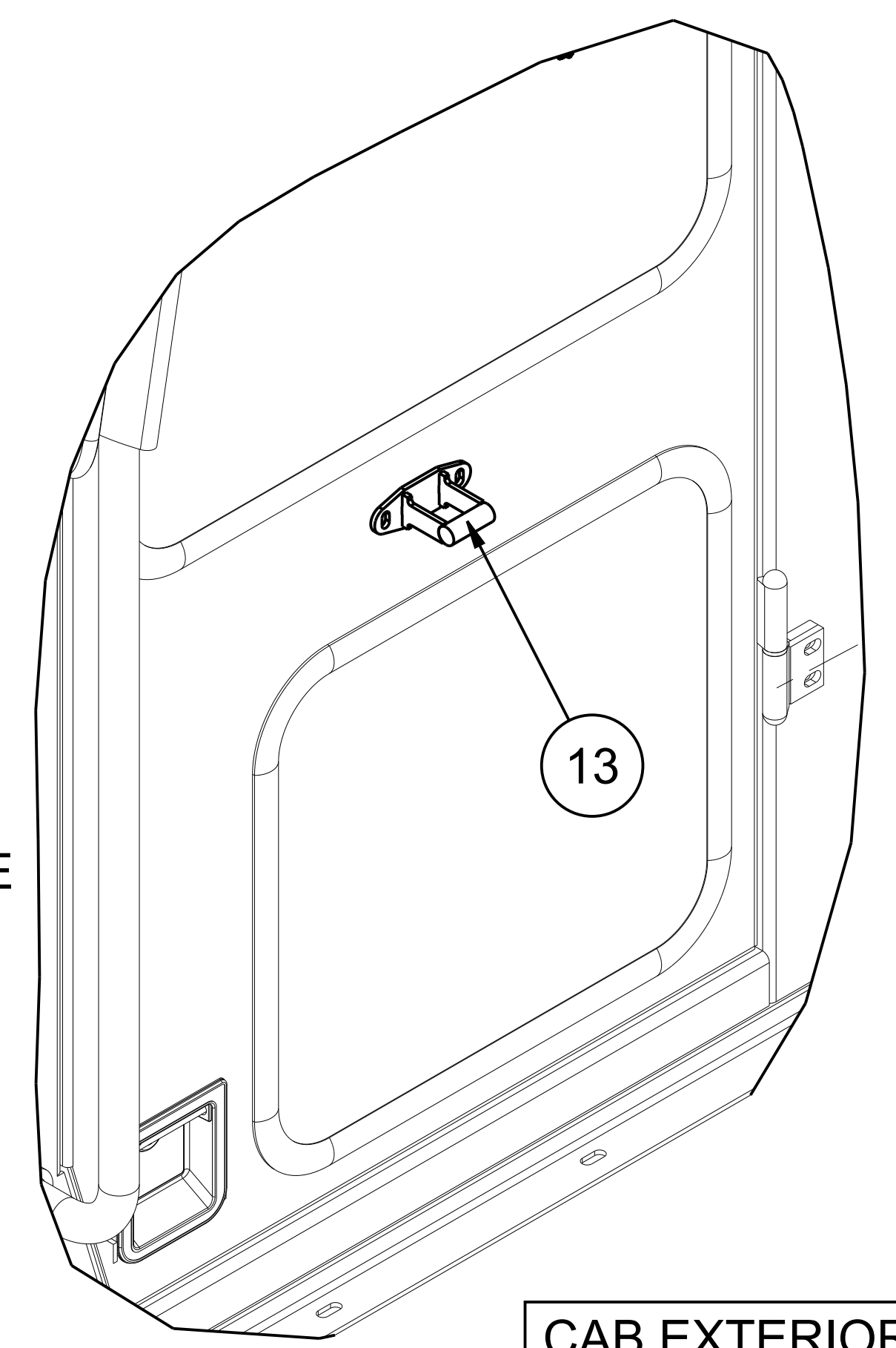
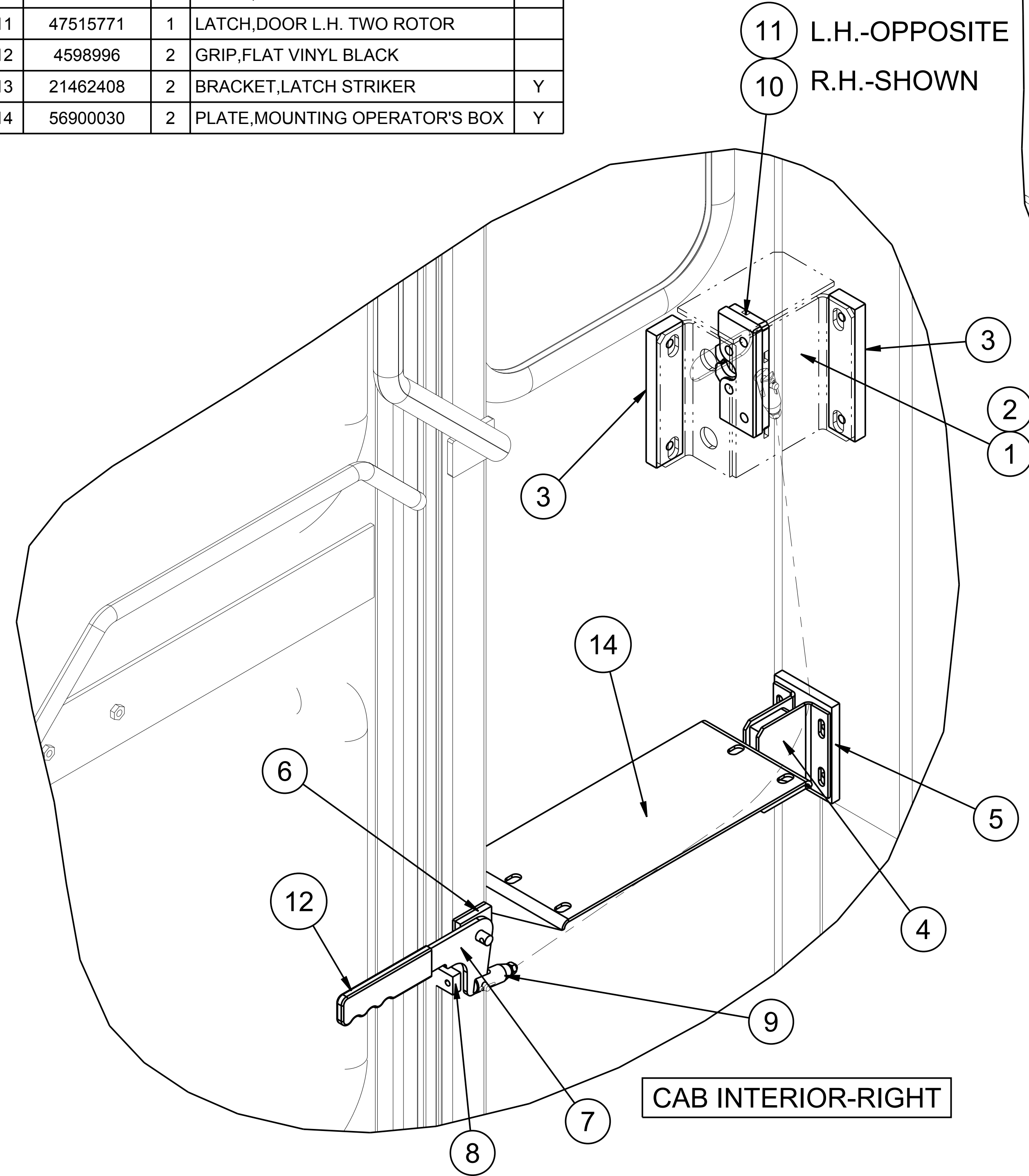

CAB EXTERIOR

CAB INTERIOR-RIGHT

CAB INTERIOR-RIGHT

REVISION HISTORY LOCATED ON LAST SHEET

CUSTOMARY: ALL DIMENSIONS IN INCHES					
IMPLIED TOLERANCES		PRODUCT: MODELS C & CX			
FRACTION	± 1/8	DESCRIPTION: SPECIFICATION, CX-BASED CAB			
X	± .06	SIZE	SCALE	DRAWING CODE NUMBER	REV.
XX	± .03	D	1/8	22224100	-
XXX	± .010	ASSEMBLY:-		SHEET 7	OF 21
MACHINE FINISH UNLESS OTHERWISE STATED					
PLANE ANGLES 90°-F°					

BASE CAB			UPPER PANELS ELECTRICAL PARTS	
ITEM NO.	PART NUMBER OR MATERIAL	QTY. REQ.	PART NAME	NORDCO DWG.
1	42350018	1	STANDARD ELECTRICAL ASSY, FULL LIGHT HARNESS COMPATABLE WITH NORDCO INSTALLED LOGIC BOX	
2	5126985	4	SWITCH, ROTARY WIPER w/BREAKER	
2.1	47174480	4	KNOB, SWITCH WINDSHIELD WIPER	
DEFROSTER FANS				
3	50211630	4	MOTOR, FAN 24V DEFROSTER	
LED DOME LIGHTS: 24V LED, RED/WHITE				
10	5190306	1	LIGHT, DOME LED w/RED/WHITE SWITCHES	
11	5190300	4	LIGHT, DOME w/SWITCH	
12	5166805	5	CONNECTOR, PLUG 3-PIN DT SERIES	
13	5112933	5	WEDGE, LOCKING PLUG 3 WAY	
14	5166798	15	SOCKET, CONTACT FEMALE 16-18GA	
15	2844443	20	SCREW, MACH #6-32 X 1.0 PAN HD	
16	3042008	20	LOCKNUT, HEX #6-32	
17	3060013	20	WASHER, SAE #6 ZINC-PLATED	
LED DOME LIGHTS: 24V, LED RED/WHITE: TO BE INSTALLED AND CONNECTED TO CAB HARNESS				

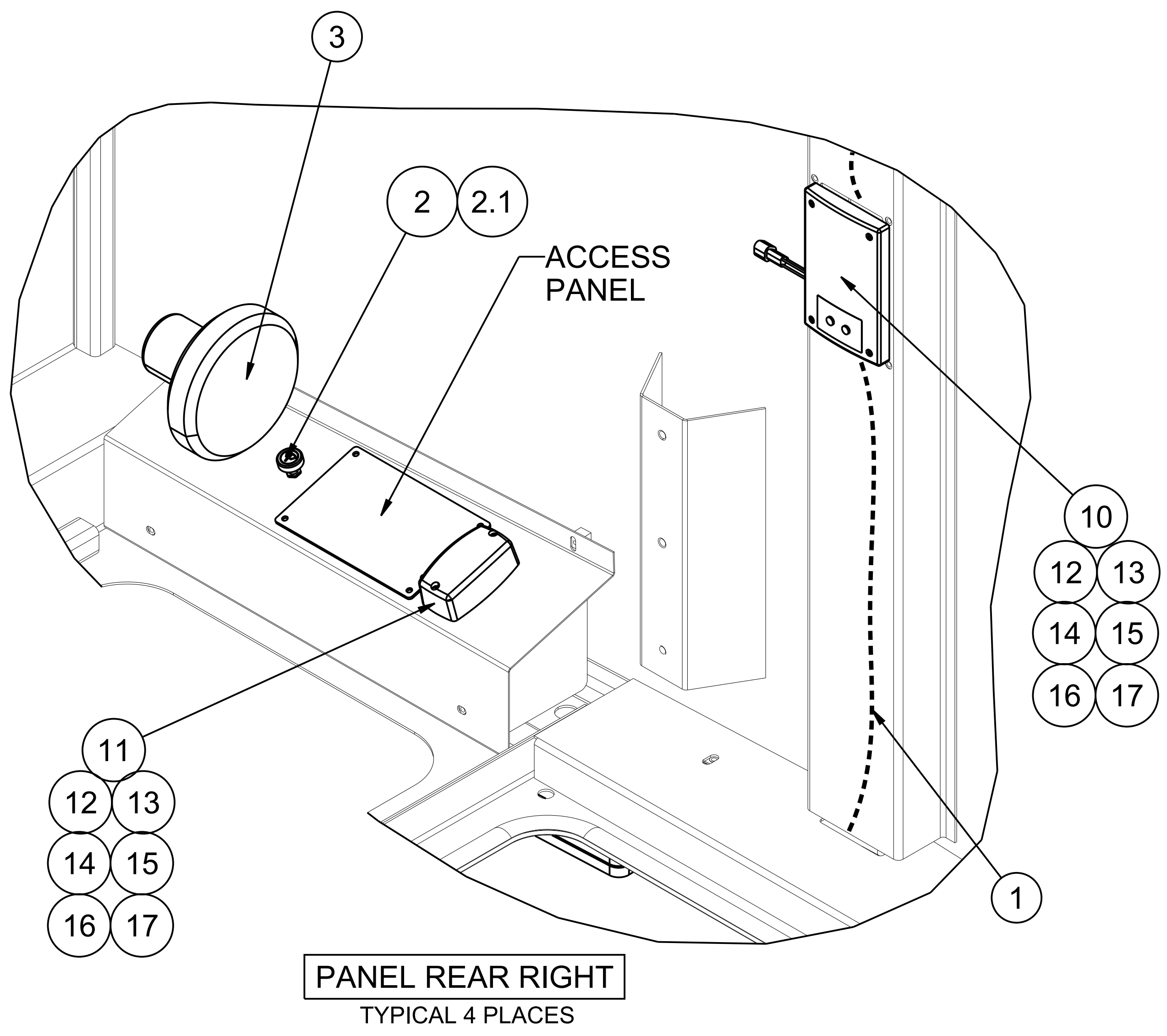

CUSTOMARY:					
ALL DIMENSIONS IN INCHES		PRODUCT: MODELS C & CX			
IMPLIED TOLERANCES		DESCRIPTION: SPECIFICATION, CX-BASED CAB			
FRACTION	± 1/8	SIZE	SCALE	DRAWING CODE NUMBER	REV.
X	± .06	D	1/8	22224100	-
XX	± .03				
XXX	± .010				
MACHINE FINISH UNLESS OTHERWISE STATED		ASSEMBLY:-		SHEET 8 OF 21	
PLANE ANGLES $\forall$ 1°					

REVISION HISTORY LOCATED ON LAST SHEET



# CAB OVERVIEW: WINDOWS LAYOUT & OPTIONS

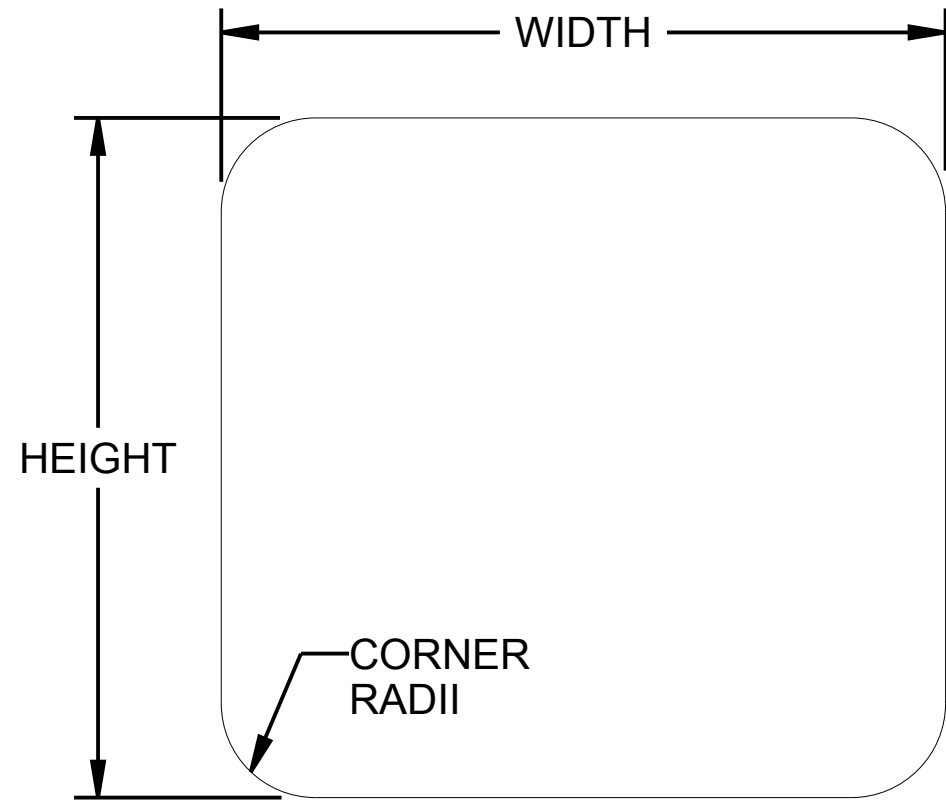

- NOTES:  
 1. ALL CORNER RADII TO BE 2.62".  
 2. POLYCARBONATE MATERIAL : ABRASION RESISTANT (BOTH SIDES).  
 3. SAFETY GLASS: LAMINATED BOTH SIDES.  
 4. TINT: GRAY 50% VISIBLE TRANSMISSION.  
 5. THICKNESS: 1/4".  
 6. REFERENCE: DRAWINGS 97491033 AND 97491037.

WINDOW PROPERTIES							
SHAPE	HEIGHT (IN)	WIDTH (IN)	POLYCARBONATE: GRAY TINT	SAFETY GLASS: GRAY TINT	SAFETY GLASS: NO TINT	GASKET	SERVICE NOTES
A	28.75	28.25	N/A	87000005	87000006	67920051 (11FT)	MUST BE SAFETY GLASS
B	37.25	10.25	22230072	87000003	87000004	67920051 (10FT)	FLAT GLASS, NO SLIDER
C	37.25	26.88	22230079	87000007	87000008	67920051 (12FT)	
D	18.88	20.12	22230080	87000009	87000012	67920051 (8FT)	
E	37.25	5.25	22230071	87000013	87000014	67920051 (9FT)	
F	28.25	20.75	N/A	87000015	87000016	67920051 (12FT)	VERIFY DIMENSIONS BEFORE PLACING ORDER
G	12.25	26.25	22230074	87000017	87000018	67920051 (8FT)	
H	10.25	26.25	22230091	87000019	87000020	67920051 (6FT)	MOD S11
I	19.25	22.75	22230092	87000021	87000022	67920051 (6FT)	MOD S12, S14
J	39.25	20.75	N/A	87000010	87000011	67920051 (12FT)	PRODUCTION DISCONTINUED VERIFY DIMENSIONS BEFORE ORDERING
K	37.25	10.25	22230300 SLIDING REAR WINDOW ASSY		22230098 LEXAN PANE		
			22230098	22230300	87000023	67920051 (10FT)	
L	TBD	28.25	N/A	87000031	87000032	67920051 (10FT)	FOR C-CX CABS (S/N 410000-S/N410199RB-UG)
M	TBD	5.25	N/A	87000033	87000034	67920051 (6FT)	

NOTE: GREY TINT SAFETY GLASS IS STANDARD IN ALL WINDOWS AS OF 2011.

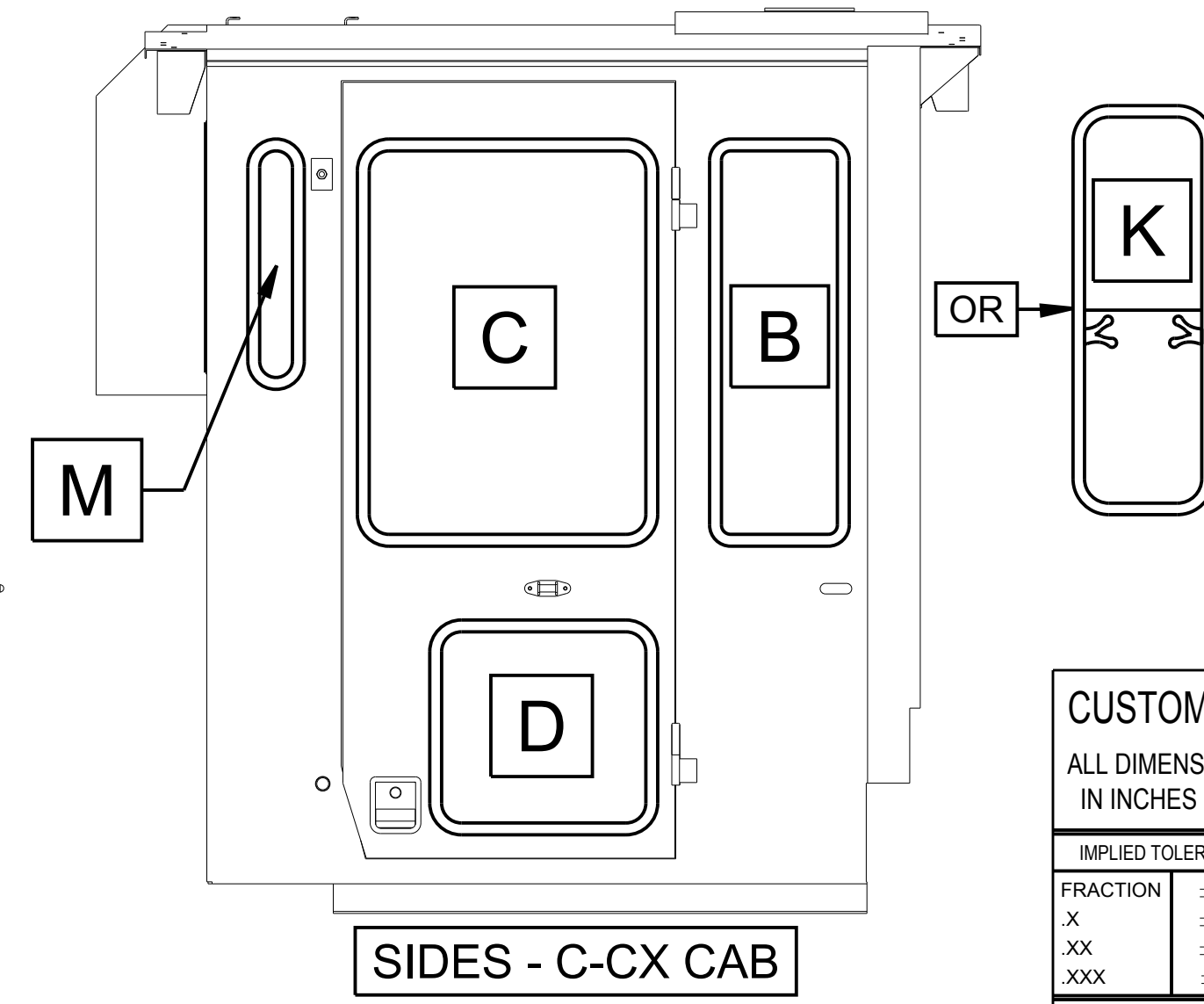
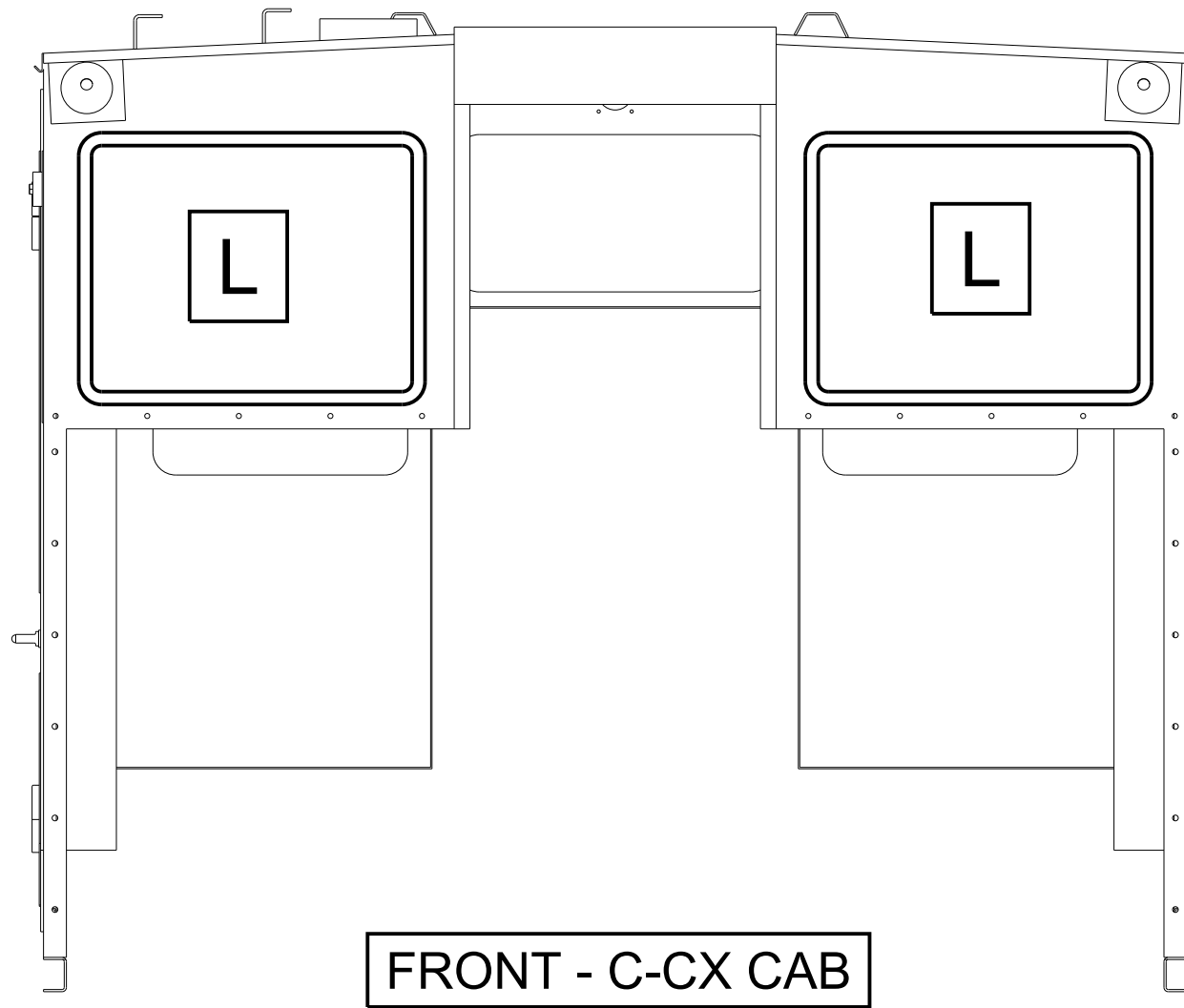
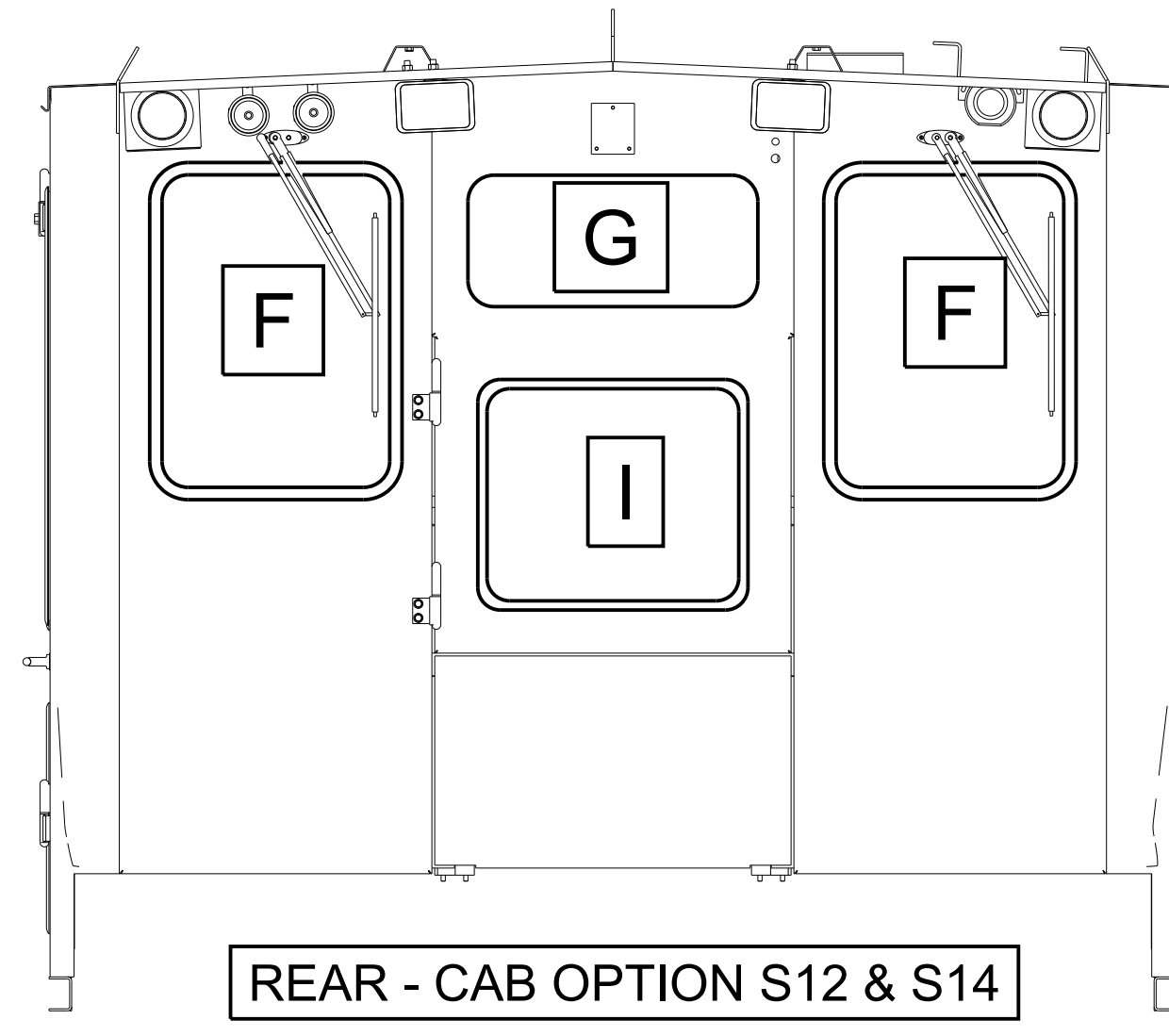
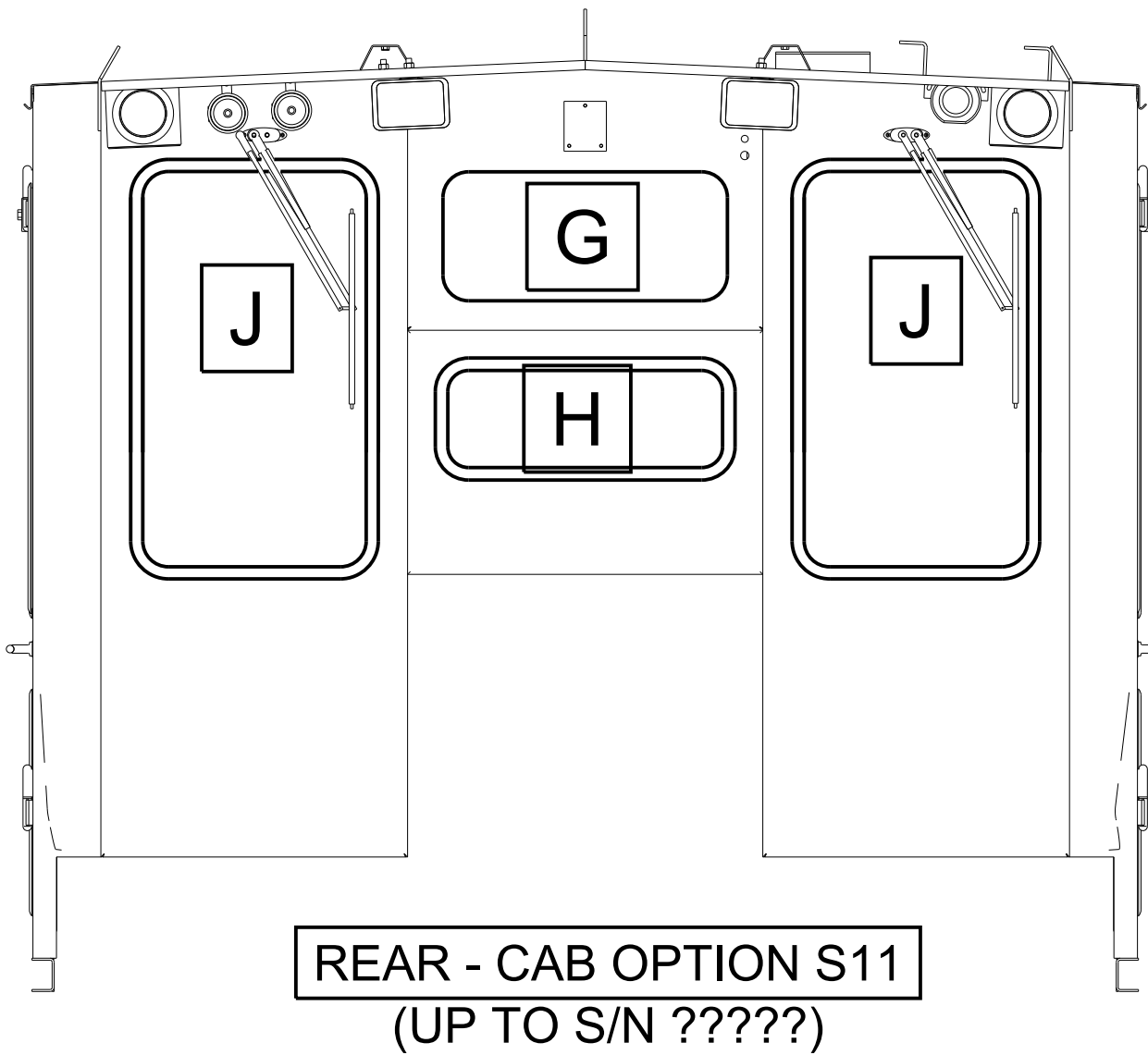
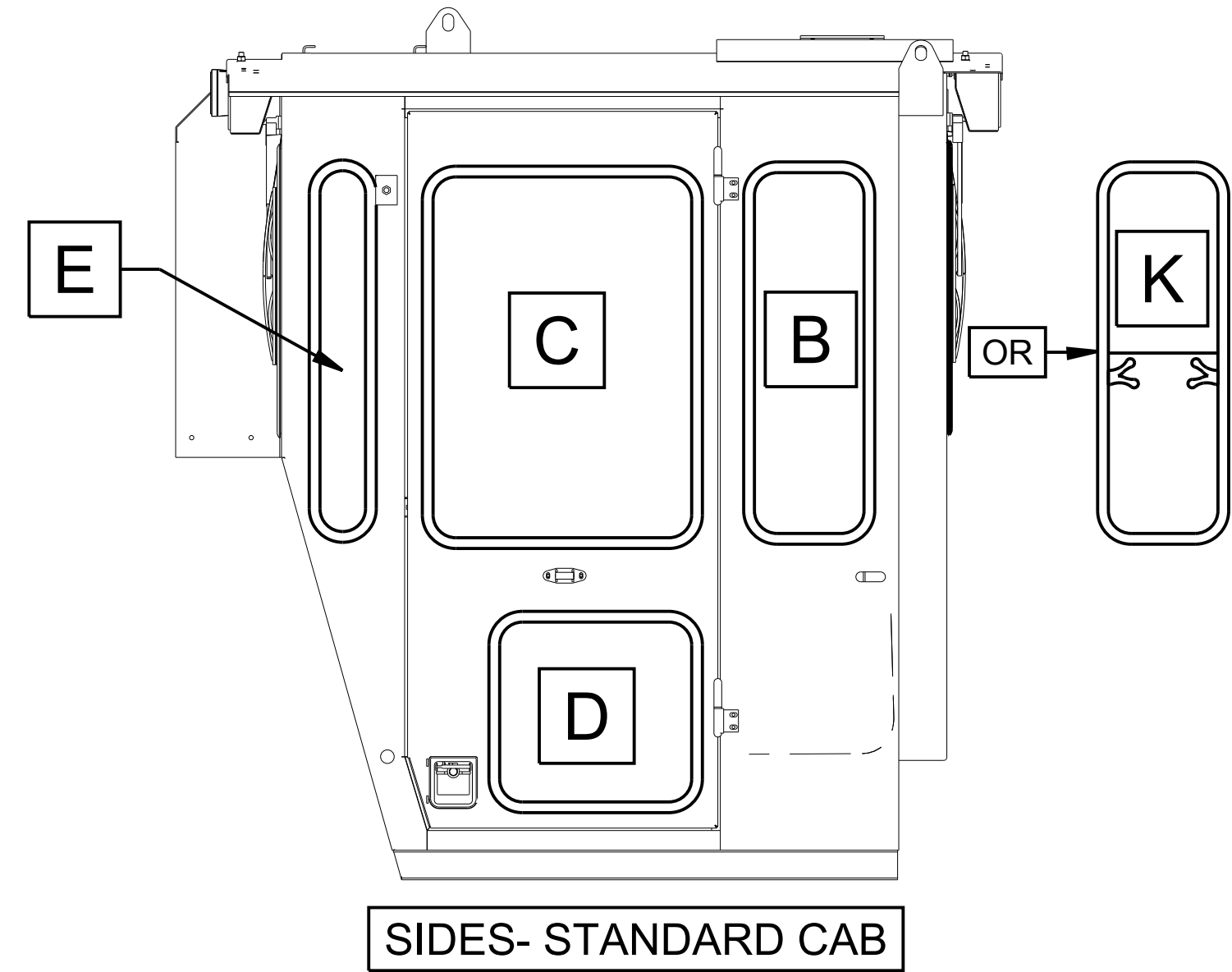
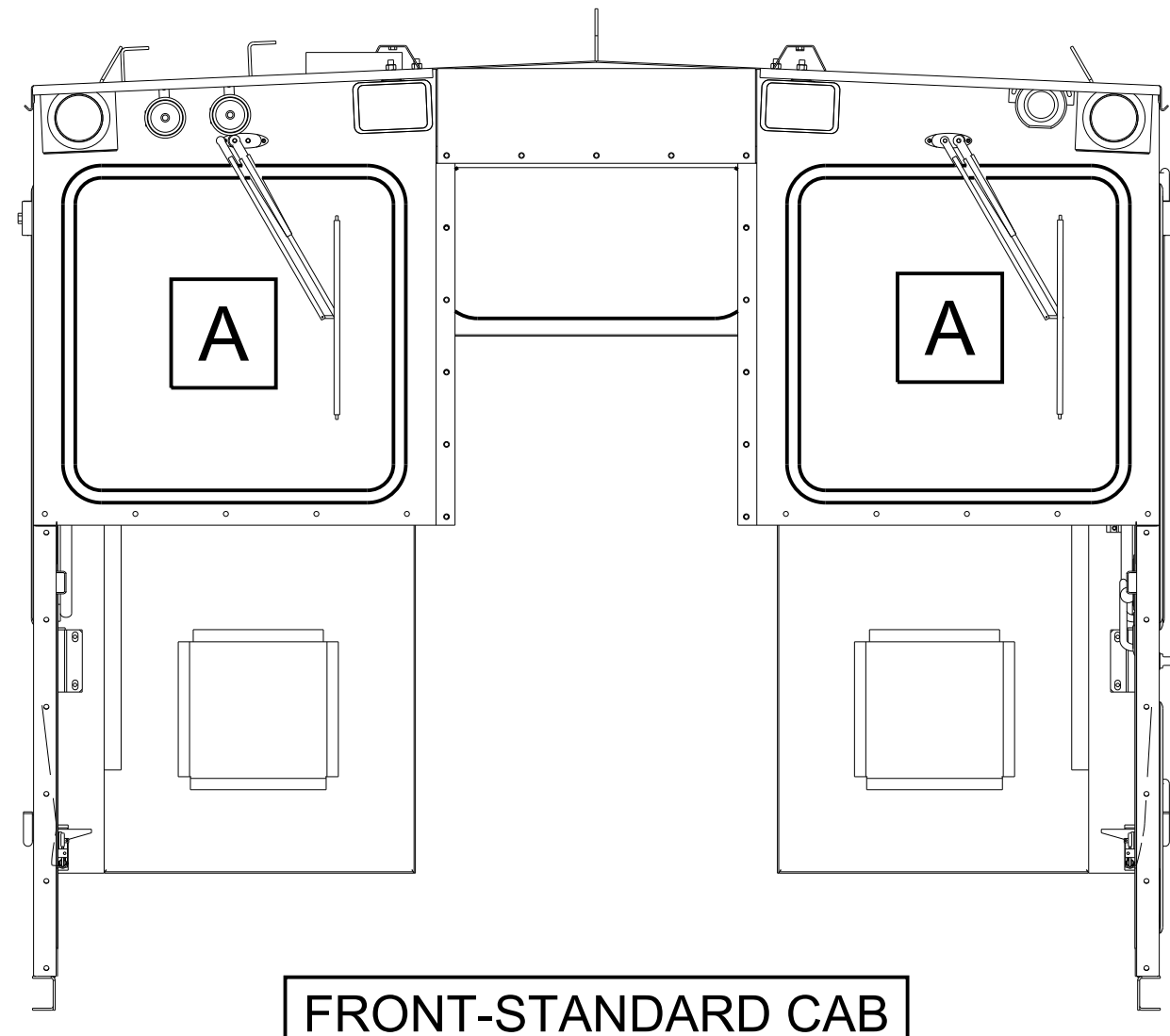

REVISION HISTORY  
LOCATED ON LAST SHEET

CUSTOMARY: ALL DIMENSIONS IN INCHES				
	PRODUCT: MODELS C & CX			
IMPLIED TOLERANCES	DESCRIPTION: SPECIFICATION, CX-BASED CAB			
FRACTION	± 1/8	SIZE	SCALE	DRAWING CODE NUMBER
X	± .06	D	1/8	22224100
XX	± .03			
XXX	± .010			
MACHINE FINISH UNLESS OTHERWISE STATED		ASSEMBLY:-	SHEET 9	OF 21

CAB OPTIONS			PAINT	
ITEM NO.	PART NUMBER OR MATERIAL	QTY. REQ.	PART NAME	NORDCO DWG.
S01			FEDERAL YELLOW	
S02			CSX GREEN	
S03			ARMOUR YELLOW	
S04			SEPTA ORANGE	

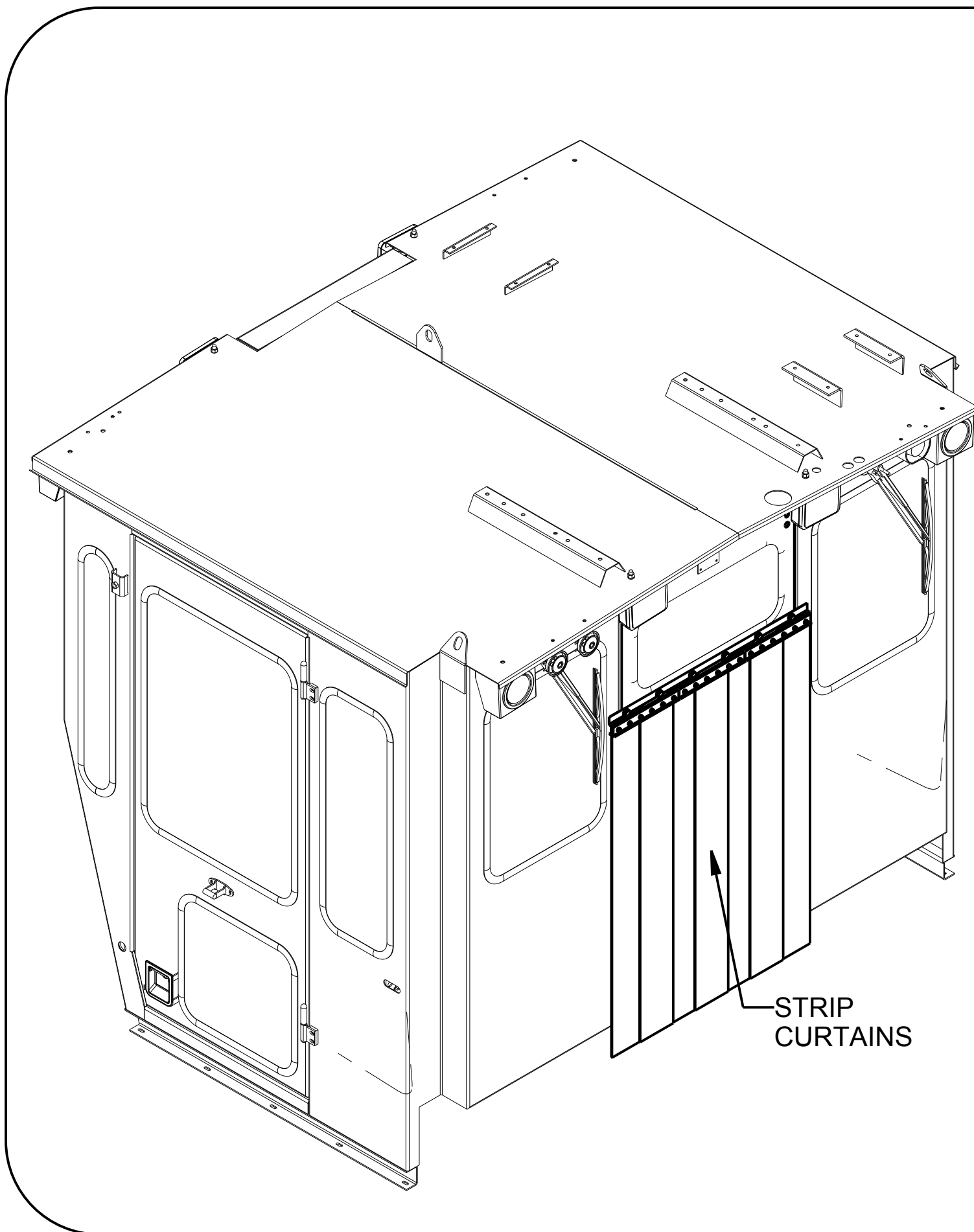
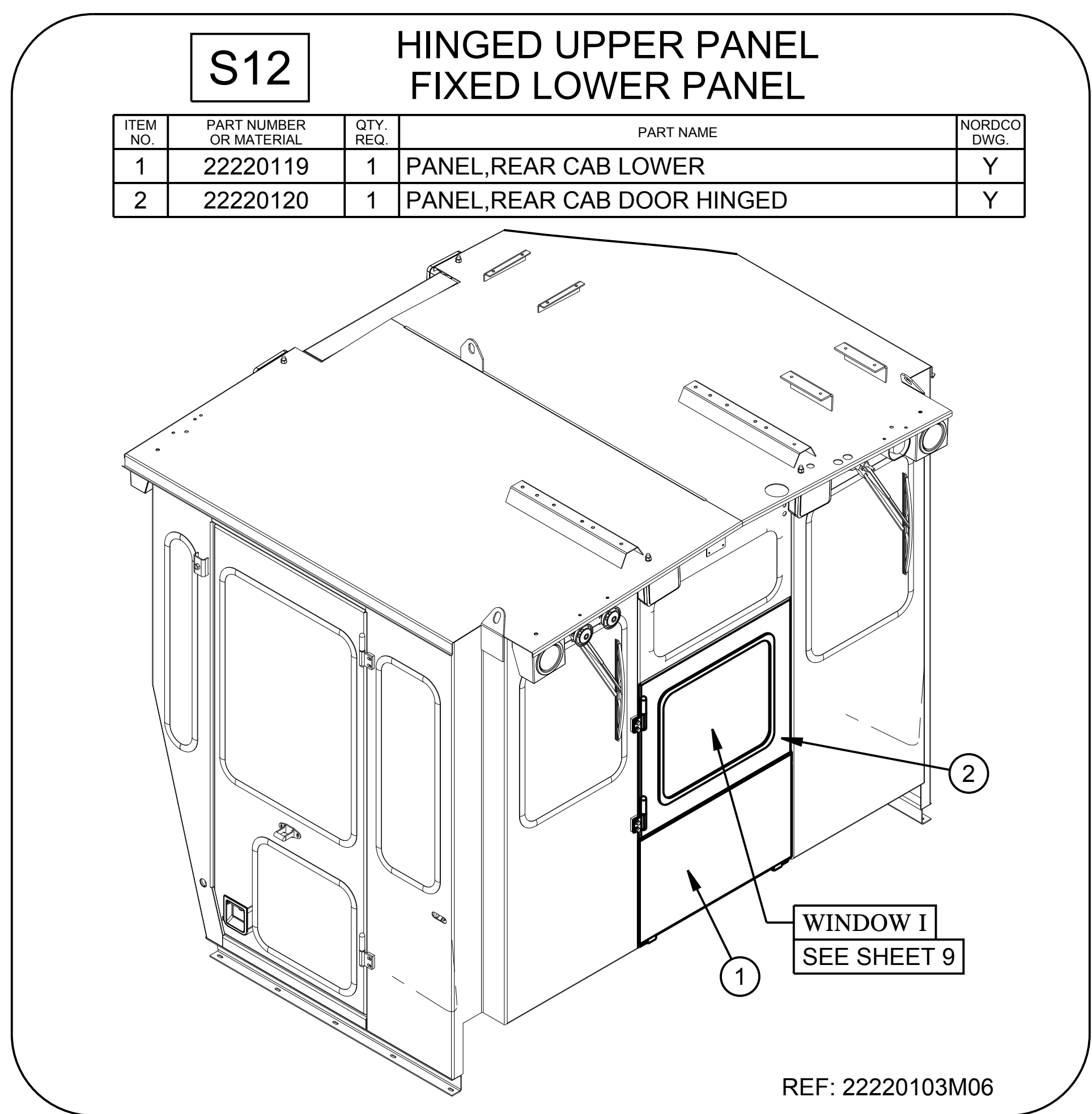
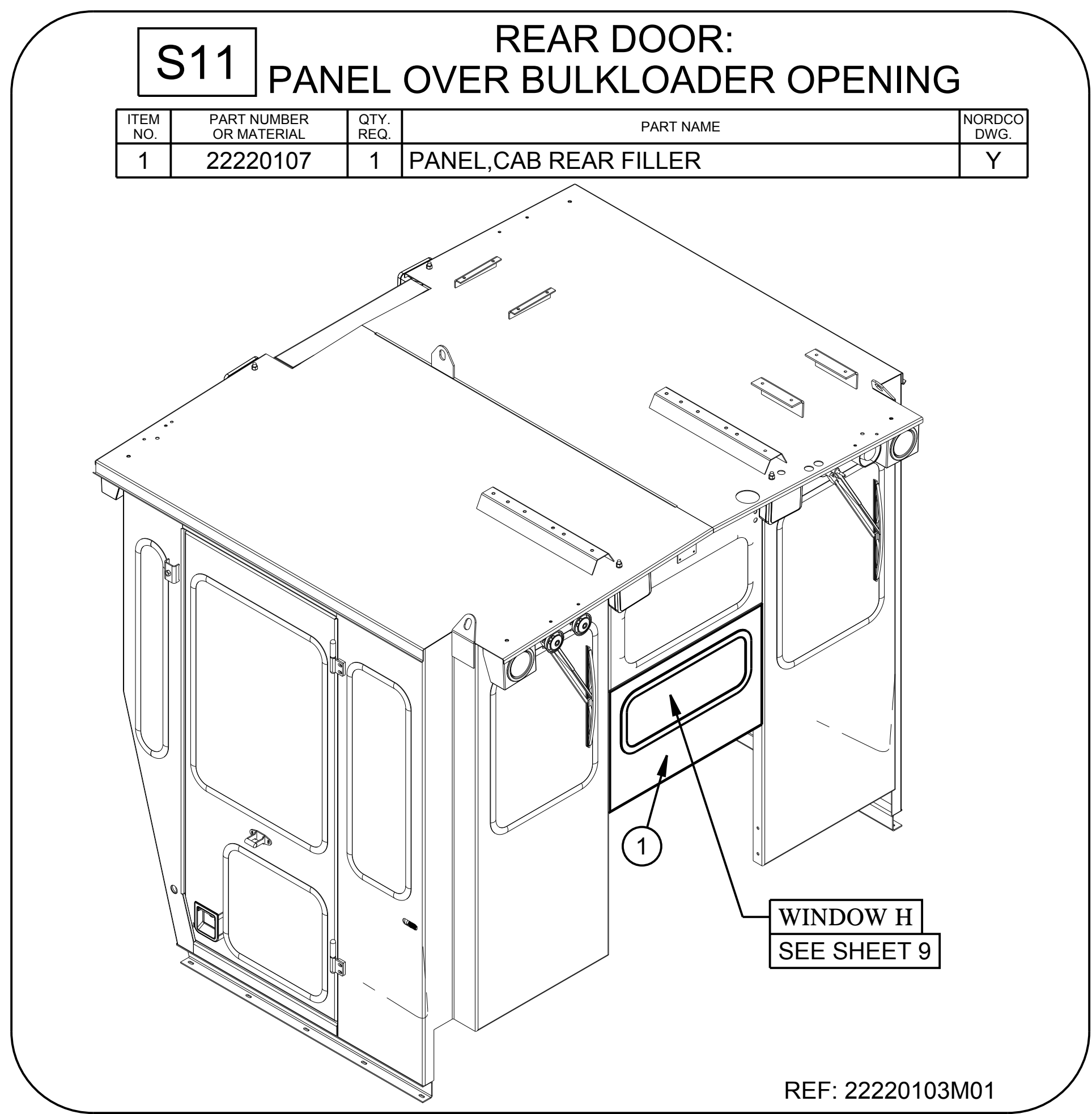

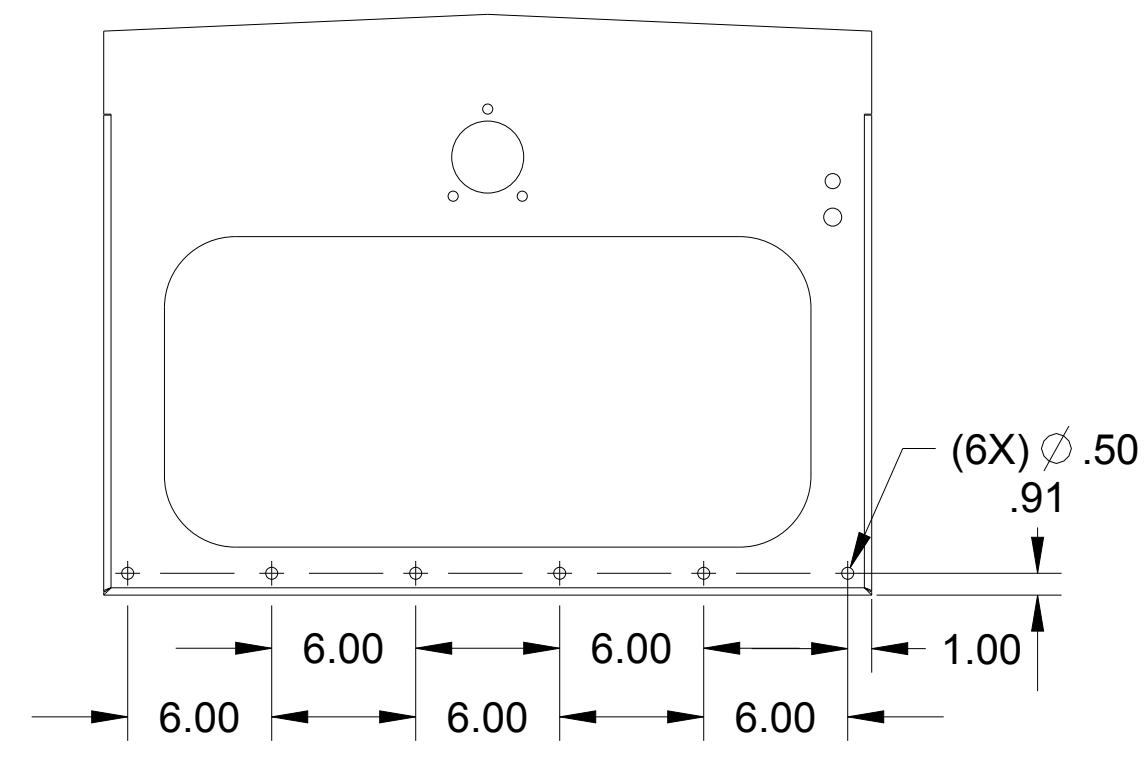

### S13 REAR DOOR: NO BULKLOADER STRIP CURTAINS

ITEM NO.	PART NUMBER OR MATERIAL	QTY. REQ.	PART NAME	NORDCO DWG.
1	21000207	1	BRACKET,WALL MOUNT DOOR HEADER	Y
2	28274130	3	CURTAIN,REAR CENTER (OUTER)	Y
3	28274131	4	CURTAIN,REAR CENTER (INNER)	Y
4	2775291	6	CAPSCREW,HEX HEAD .50-13UNC X 1.25	
5	3060476	12	WASHER,STANDARD .50	
6	3064476	6	WASHER,LOCK .50	
7	3001031	6	NUT,HEX .50-13UNC	

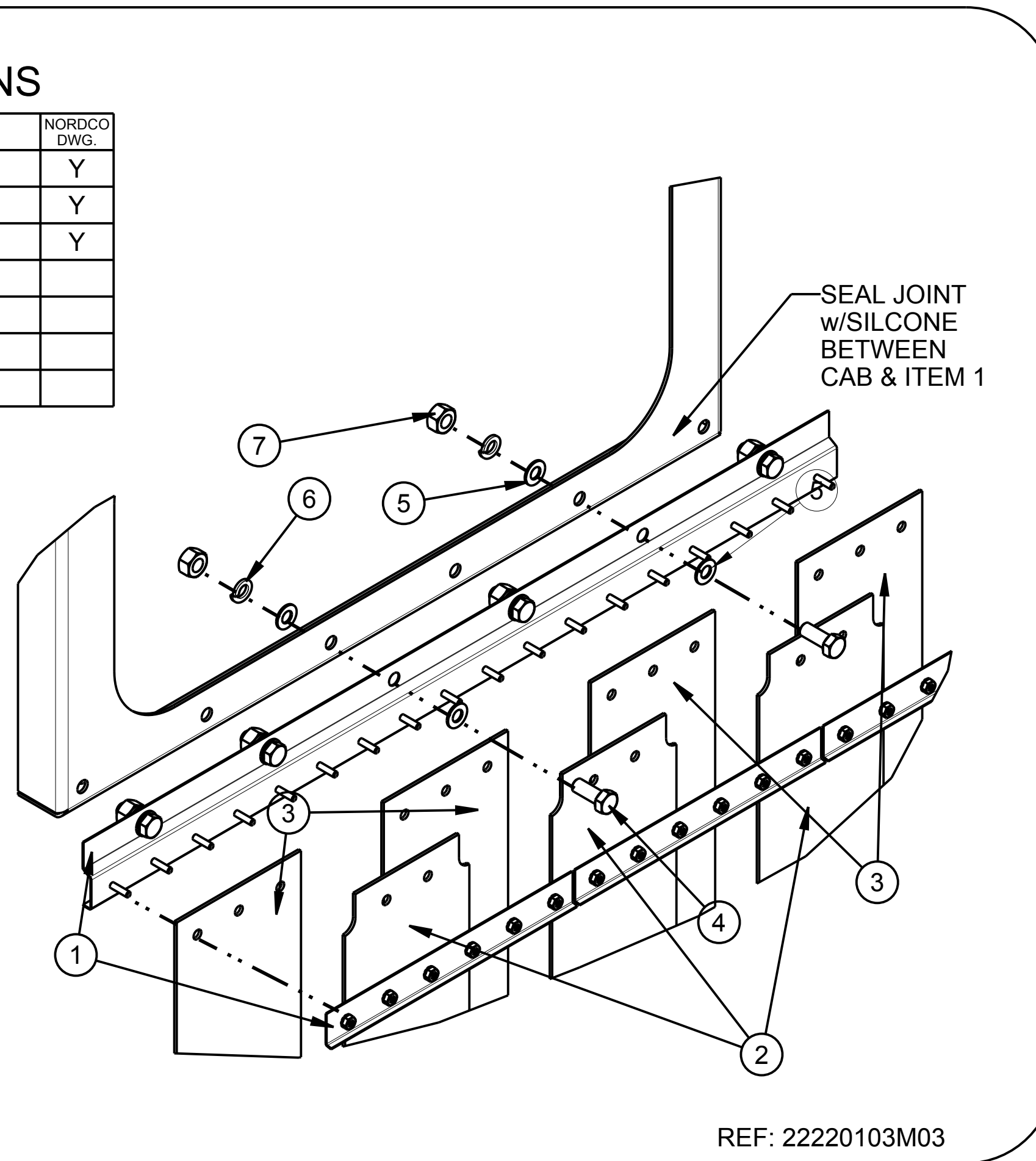

REAR CENTER PANEL MODIFICATION

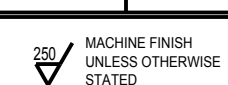

CUSTOMARY: ALL DIMENSIONS IN INCHES			 THIRD ANGLE PROJECTION
	PRODUCT: MODELS C & CX		
IMPLIED TOLERANCES	DESCRIPTION: SPECIFICATION, CX-BASED CAB		
FRACTION ± 1/8	SIZE	SCALE	DRAWING CODE NUMBER
X ± .06	D 1/8	1/8	22224100
XX ± .03			
XXX ± .010			
 MACHINE FINISH UNLESS OTHERWISE STATED	ASSEMBLY:-	SHEET 10 OF 21	

REVISION HISTORY LOCATED ON LAST SHEET

**S14** FIXED REAR PANEL FULLY ENCLOSED

ITEM NO.	PART NUMBER OR MATERIAL	QTY. REQ.	PART NAME	NORDCO DWG.
1	22220123	1	PANEL, REAR FULL FIXED	Y

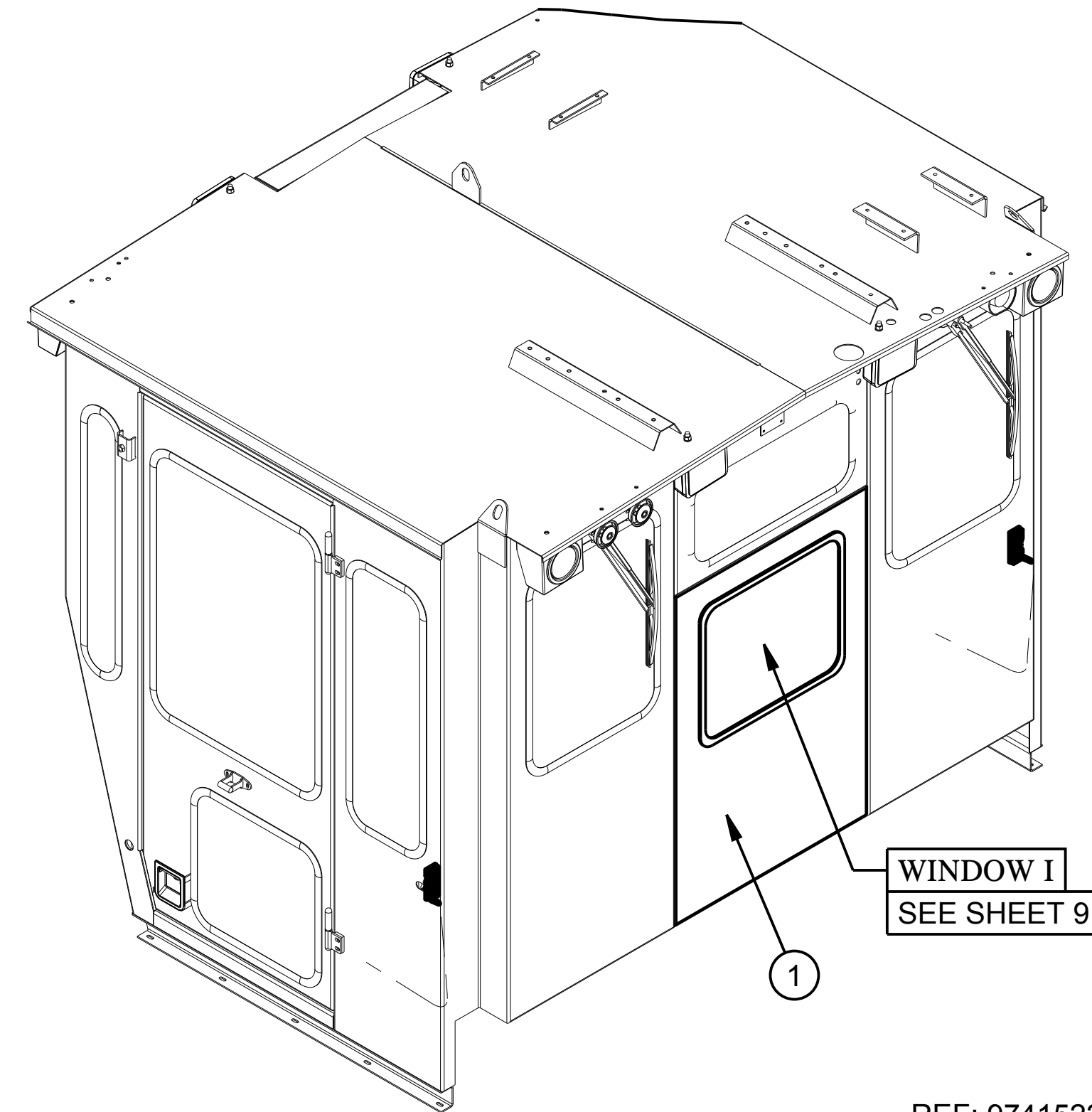

REF: 97415220

**S15** REAR OPENING: BLACK CURTAIN

ITEM NO.	PART NUMBER OR MATERIAL	QTY. REQ.	PART NAME	NORDCO DWG.
1	8015030	2	VELCRO, HOOK 2" BLACK SELF-ADHESIVE 48" LG	
2	3114192	16	SCREW, TAPPING #8-3/8 HEX FL HD	
3	28274146	1	CURTAIN, REAR CENTER CAB BLACK	Y
4	2775291	6	CAPSCREW, HEX HEAD .50-13UNC X 1.25	
5	3060476	12	WASHER, STANDARD .50	
6	3001031	6	NUT, HEX .50-13UNC	

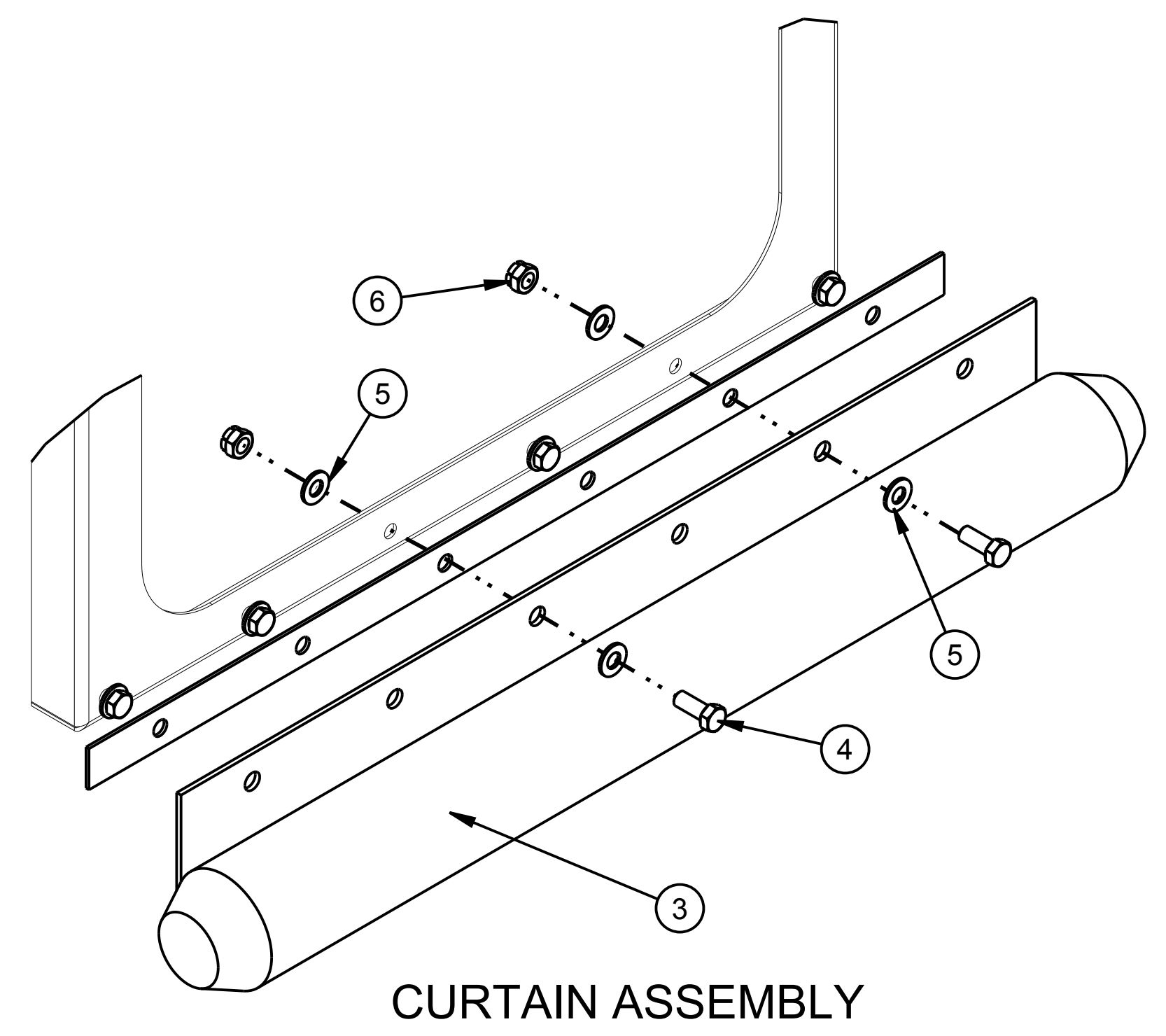
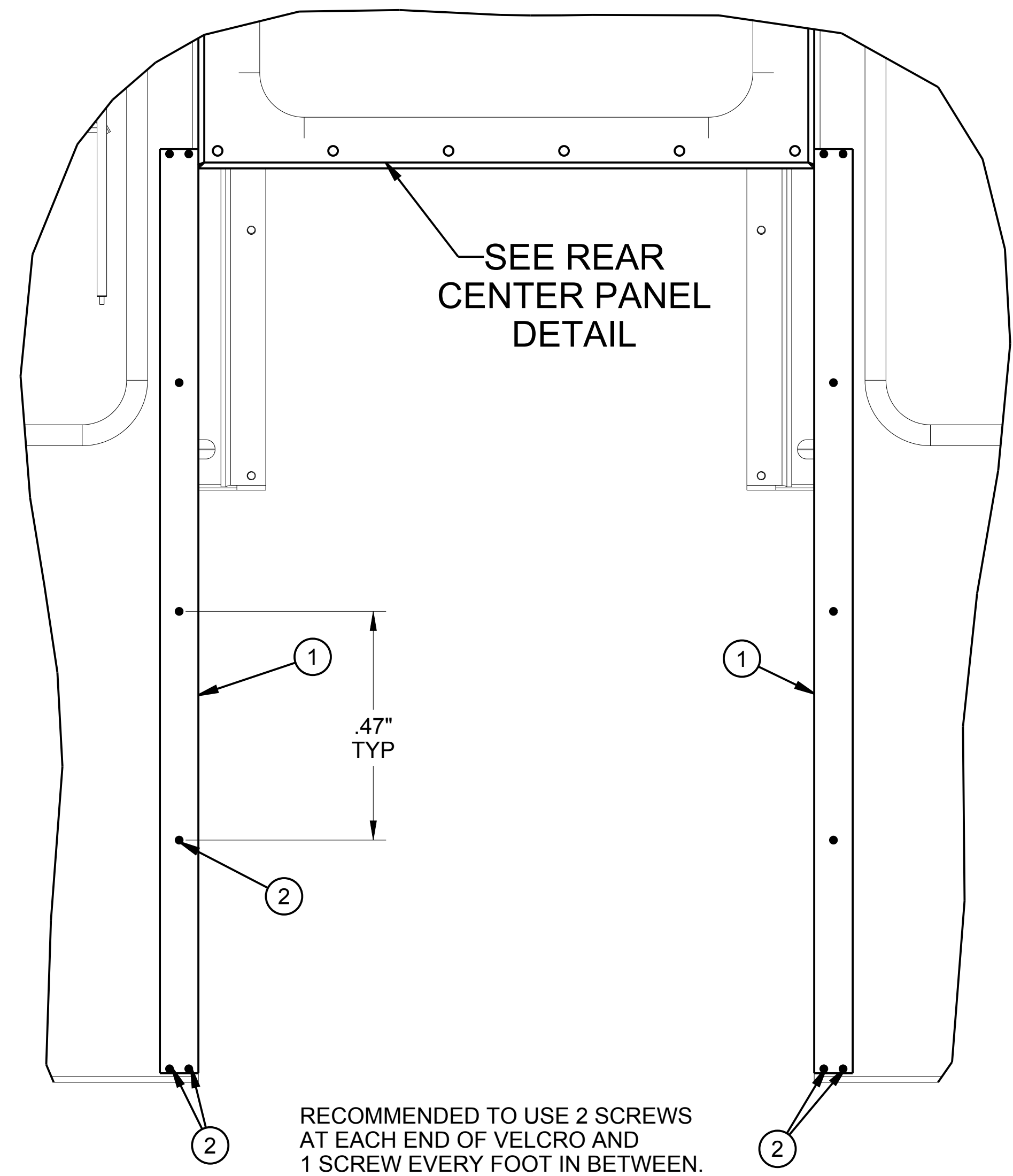

CURTAIN ASSEMBLY

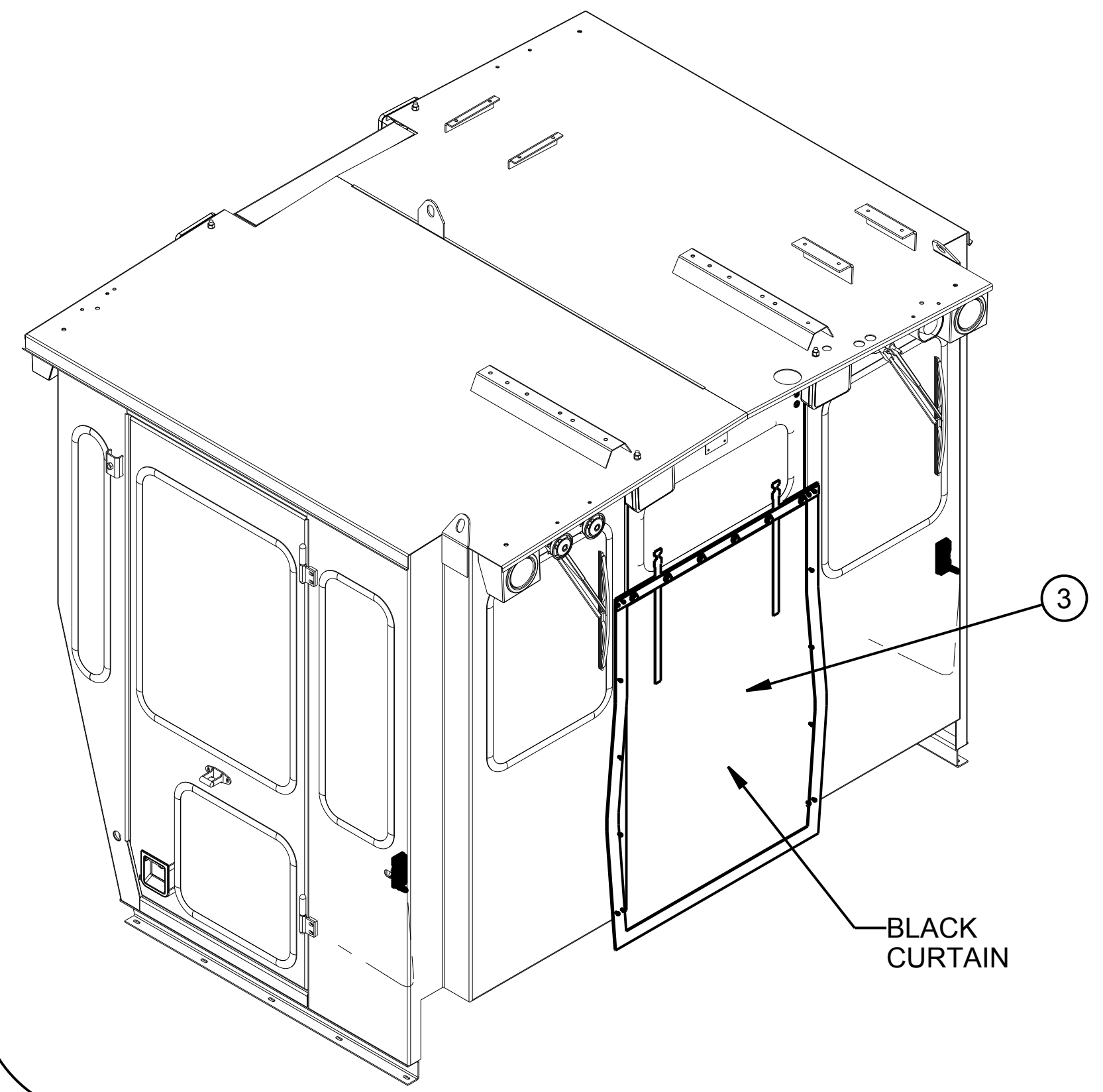

BLACK CURTAIN

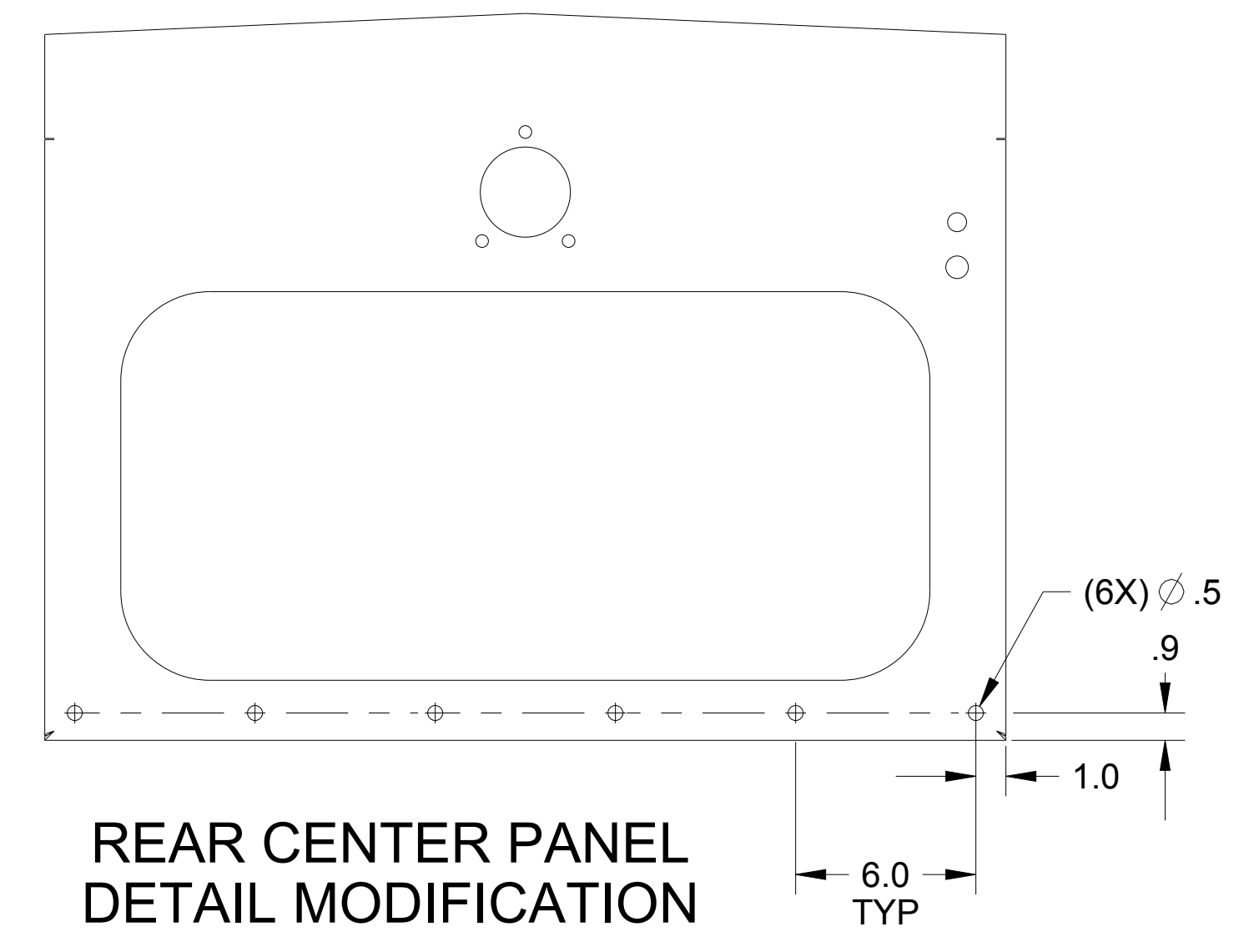

REAR CENTER PANEL DETAIL MODIFICATION

REF: 96412437

CUSTOMARY: ALL DIMENSIONS IN INCHES				THIRD ANGLE PROJECTION	
IMPLIED TOLERANCES		PRODUCT: MODELS C & CX			
FRACTION	± 1/8	DESCRIPTION: SPECIFICATION, CX-BASED CAB			
X	± .06	SIZE	SCALE	DRAWING CODE NUMBER	REV.
XX	± .03	D	1/8	22224100	-
XXX	± .010	ASSEMBLY:-		SHEET 11 OF 21	
MACHINE FINISH UNLESS OTHERWISE STATED		PLANE ANGLES 90°-1°			

REVISION HISTORY LOCATED ON LAST SHEET

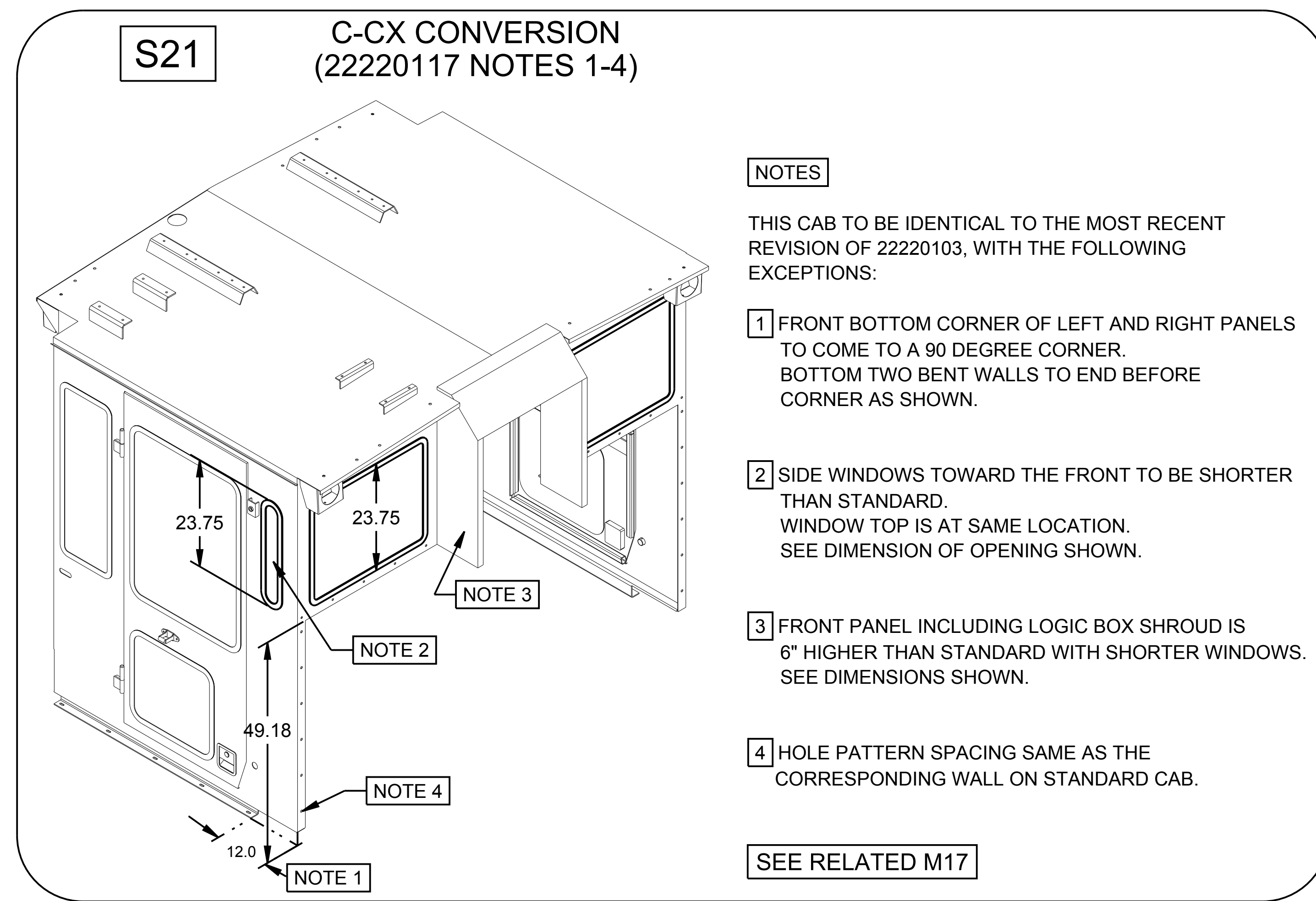
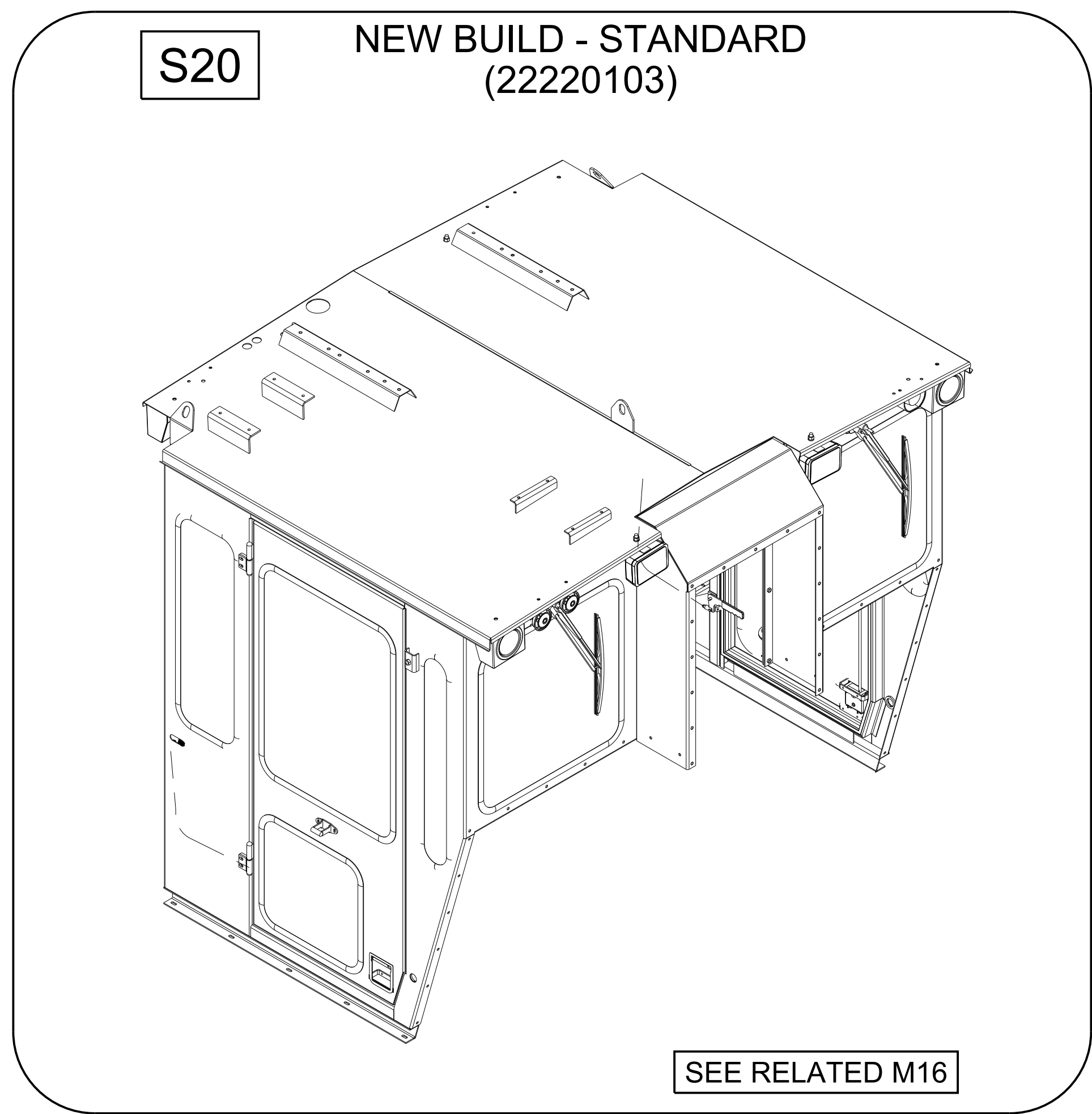

**NOTES**

THIS CAB TO BE IDENTICAL TO THE MOST RECENT REVISION OF 22220103, WITH THE FOLLOWING EXCEPTIONS:

- 1 FRONT BOTTOM CORNER OF LEFT AND RIGHT PANELS TO COME TO A 90 DEGREE CORNER. BOTTOM TWO BENT WALLS TO END BEFORE CORNER AS SHOWN.
- 2 SIDE WINDOWS TOWARD THE FRONT TO BE SHORTER THAN STANDARD. WINDOW TOP IS AT SAME LOCATION. SEE DIMENSION OF OPENING SHOWN.
- 3 FRONT PANEL INCLUDING LOGIC BOX SHROUD IS 6" HIGHER THAN STANDARD WITH SHORTER WINDOWS. SEE DIMENSIONS SHOWN.
- 4 HOLE PATTERN SPACING SAME AS THE CORRESPONDING WALL ON STANDARD CAB.

CUSTOMARY: ALL DIMENSIONS IN INCHES				THIRD ANGLE PROJECTION	
IMPLIED TOLERANCES		PRODUCT: MODELS C & CX			
FRACTION	± 1/8	DESCRIPTION: SPECIFICATION, CX-BASED CAB			
X	± .06	SIZE	SCALE	DRAWING CODE NUMBER	REV.
XX	± .03	D	1/8	22224100	-
XXX	± .010	ASSEMBLY:-		SHEET 12 OF 21	
MACHINE FINISH UNLESS OTHERWISE STATED		PLANE ANGLES 90°-1°			

REVISION HISTORY LOCATED ON LAST SHEET

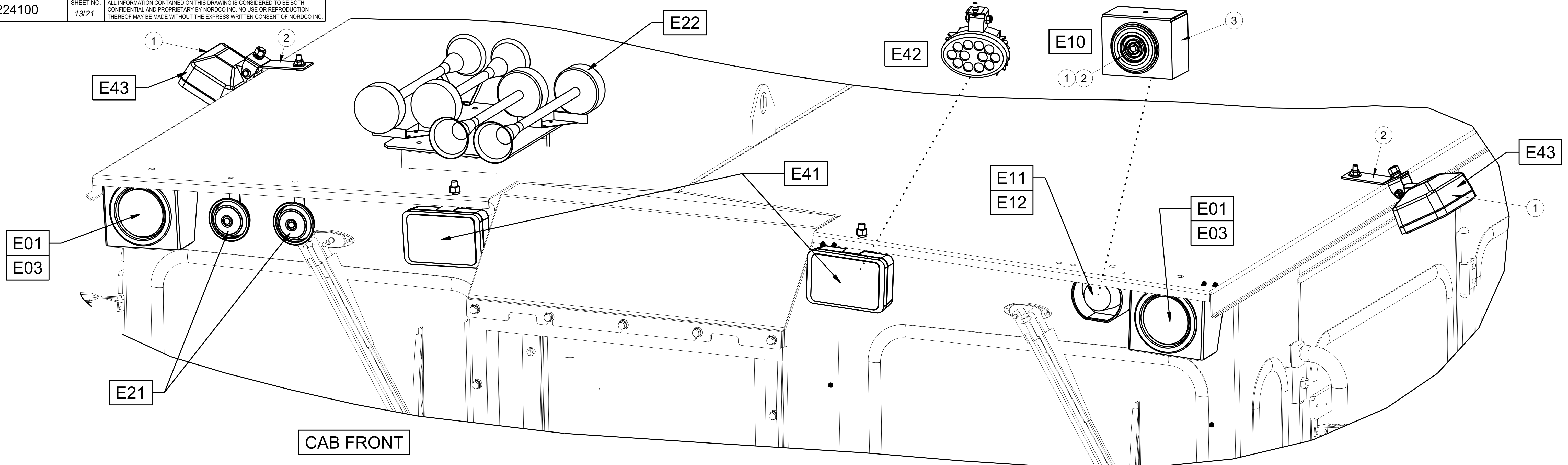

CAB FRONT

CAB OPTIONS		BRAKE LIGHTS: LED		
ITEM NO.	PART NUMBER OR MATERIAL	QTY. REQ.	PART NAME	NORDCO DWG.
<b>E01</b>		BRAKE/MARKER		
1	5190451	4	LIGHT, MARKER/BRAKE, LED, RED 24V GROMMET MOUNTED, 4" 3-WIRE	
2	5190440	4	GROMMET, 4"	
3	5166789	2	PLUG, LIGHT, RIGHT ANGLE 3-PIN MOLDED CONNECTOR W/3 WIRES, 10" LG.	
<b>E03</b>		BRAKE/MARKER (BN SPECIAL)		
1	5190510	4	LIGHT, MARKER/BRAKE 24V LED	
2	5190440	4	GROMMET, 4"	
3	5166789	2	PLUG, LIGHT RIGHT ANGLE 3-PIN MOLDED CONNECTOR W/3 WIRES, 10" LG.	

CAB OPTIONS		BACKUP ALARMS		
ITEM NO.	PART NUMBER OR MATERIAL	QTY. REQ.	PART NAME	NORDCO DWG.
<b>E10</b>		STANDARD		
1	5190068	2	ALARM, BACK-UP 24V GROMMET MOUNTED, 4", 3-WIRE	
2	5190440	2	GROMMET, 4"	
3	640254	2	GROMMET MOUNTED LIGHT BOXES, SINGLE	
4	640253	2	GROMMET MOUNTED LIGHT BOXES, DOUBLE	
<b>E11</b>		SMART (BN)		
1	5190065	2	ALARM, BACK-UP SMART BRACKET MOUNTED 12-24V	
2	640254	4	GROMMET MOUNTED LIGHT BOXES, SINGLE	
<b>E12</b>		PRECO (CSX)		
1	5190069	2	ALARM, BACK-UP ADJ. VOLUME CSX	
2	640254	4	GROMMET MOUNTED LIGHT BOXES, SINGLE	

E21		HORNS: TWEETER		
ITEM NO.	PART NUMBER OR MATERIAL	QTY. REQ.	PART NAME	NORDCO DWG.
1	5190017	2	HORN, LOW TONE	
2	5190015	2	HORN, HIGH TONE	
3	21459505	4	BRACKET, HORN	

**HORNS: TWEETER INSTRUCTIONS:**

1. MOUNT 2 TWEETER HORNS TO ROOF OF CAB (E21).
2. SECURE WIRES WITH WIRE CLAMPS BOLTED TO WELD STUDS.

E22		HORNS: DUAL TRUMPET STYLE		
ITEM NO.	PART NUMBER OR MATERIAL	QTY. REQ.	PART NAME	NORDCO DWG.
1	5190040	2	HORN, ELEC 24V, TWIN TRUMPET	
2	21462416	1	BRACKET, ROOF HORN MTG	Y
3	2837631	6	MACH SCR, #10-24 X .75	
4	3060458	6	WASHER SAE #10	
5	3042011	6	LOCKNUT, HEX #10-24	
6	2774791	4	HHCS .38-16UNC X 1.25	
7	3060470	4	WASHER SAE .38	
8	3042020	4	LOCKNUT HEX .38-16UNC	
9	42350097	1	HARNES, DUAL TRUMPET HORNS	Y

**HORNS: TRUMPET INSTRUCTIONS:**

1. ATTACH 2 SETS OF HORNS TO MTG PLATE w/WIRES & PACKARD CONNECTOR OUT THE BOTTOM. (2-WAY SHROUD, MALE PINS)
2. ATTACH MTG PLATE ASSEMBLY TO CAB ROOF MTG HOLE AT CAB FRONT.
3. INSTALL GROMMET INTO STD-HORN ROOF MTG HOLE AT CAB FRONT.
4. ATTACH PACKARD TO SINGLE END OF HORN HARNESS. (2-WAY TOWER, FEMALE PINS)
5. CONNECT TO MATING PACKARD FROM STEP 1.
6. SECURE WIRES TO WIRE CLAMPS BOLTED TO WELD STUDS ACROSS ROOF

CAB OPTIONS		TRAVEL LIGHTS		
ITEM NO.	PART NUMBER OR MATERIAL	QTY. REQ.	PART NAME	NORDCO DWG.
<b>E41</b>		HALOGEN SPOT		
1	5190432	4	LIGHT, TRAVEL 24V HALOGEN w/PACKARD	Y
1.1	5190432098	4	LIGHT, TRAVEL 24V HALOGEN w/o PACKARD	
1.2	5190956	4	LAMP, 4X6 HALOGEN SPOT 24V	
1.3	5166782	8	TERMINAL, MALE PIN WEATHER PROOF	
1.4	5166772	4	CONNECTOR, PACKARD WEATHER PACK	
<b>E42</b>		LED SPOT		
1	5190351	4	LIGHT, TRAVEL 12/23V LED SPOT	

E43		BOARDING LIGHTS		
ITEM NO.	PART NUMBER OR MATERIAL	QTY. REQ.	PART NAME	NORDCO DWG.
1	5190422	2	LIGHT, WORK 24V HALOGEN 4X6	Y
1.1	5190422-098	2	LIGHT, WORK 24V HALOGEN w/o PACKARD	
1.2	5166781	4	TERMINAL, MALE PIN WEATHER PROOF	
1.3	5166772	2	CONNECTOR, PACKARD WEATHER PACK	
2	21000255	2	BRACKET, CAB PERIMETER LIGHT	Y

**CUSTOMARY:**  
 ALL DIMENSIONS IN INCHES  
 IMPLIED TOLERANCES:  
 FRACTION ± 1/8  
 X ± .06  
 XX ± .03  
 XXX ± .010  
 MACHINE FINISH UNLESS OTHERWISE STATED  
 PLANE ANGLES W/ F°

**Nordco**  
 PRODUCT: MODELS C & CX  
 DESCRIPTION: SPECIFICATION, CX-BASED CAB  
 SIZE SCALE DRAWING CODE NUMBER REV  
**D 1/8 22224100 -**  
 ASSEMBLY: SHEET 13 OF 21

THIRD ANGLE PROJECTION

REVISION HISTORY LOCATED ON LAST SHEET

E23		HORNS: REMOTE HORN BUTTON		
ITEM NO.	PART NUMBER OR MATERIAL	QTY. REQ.	PART NAME	NORDCO DWG.
1	5126095	2	SWITCH,HORN HD WATERTIGHT	
2	5103815	2	CONN,CABLE STR .25-.38 1/2NPT	
3	5270228	50'	CORD SO 16/2C BLK-WHT	
4	2774311	4	CPSCR,HX HD 1/4-20 X 1.75	
5	3064464	4	WASHER LOCK .250	

**REMOTE HORN BUTTON INSTRUCTIONS:**

1. DRILL (2)  $\phi$ .281 HOLES. **DETAIL A**
2. INSTALL HORN BUTTONS WITH CABLE WIRES EXTENDING FORWARD.
3. REPEAT FOR OTHER SIDE OF CAB.

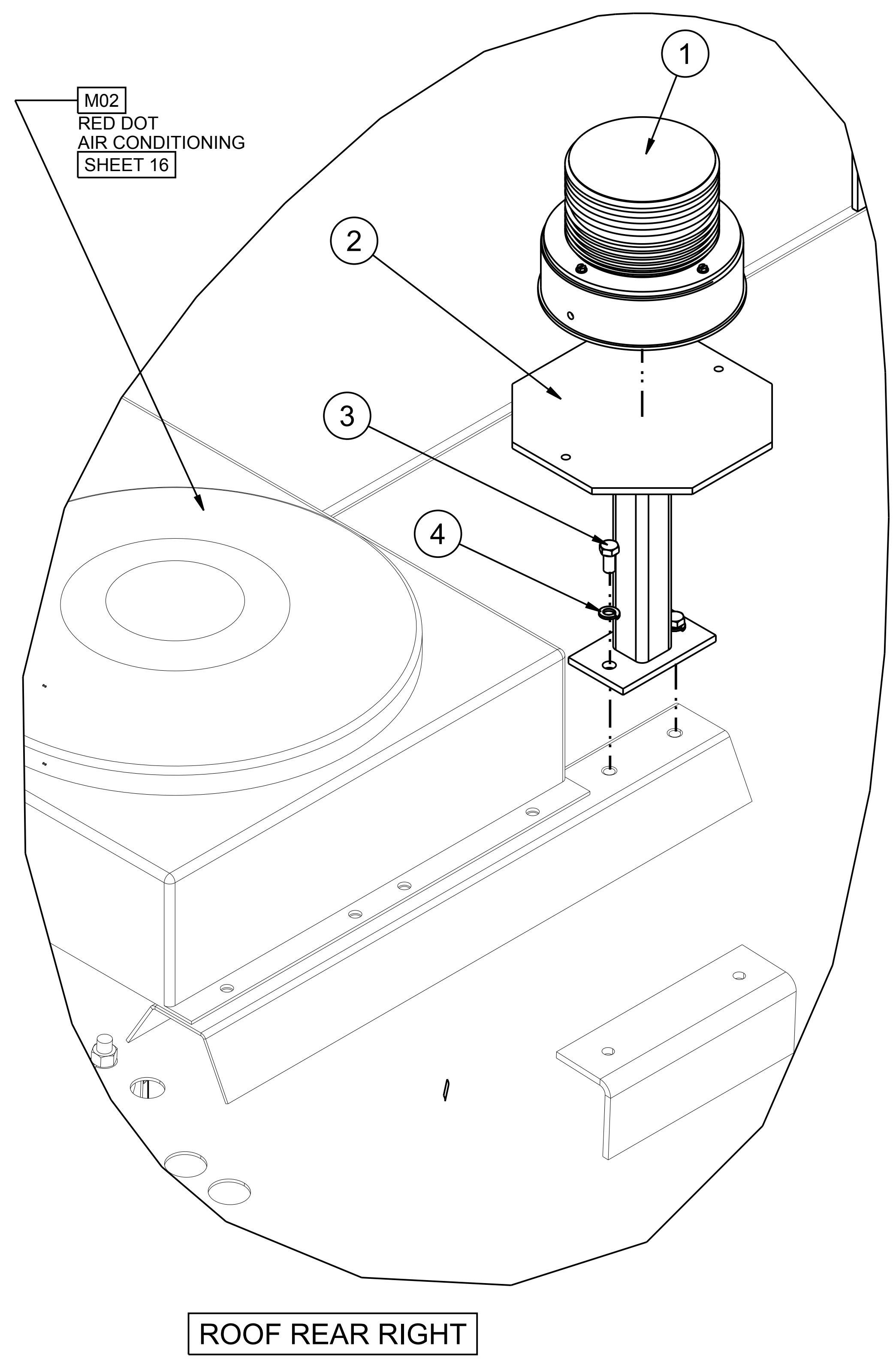
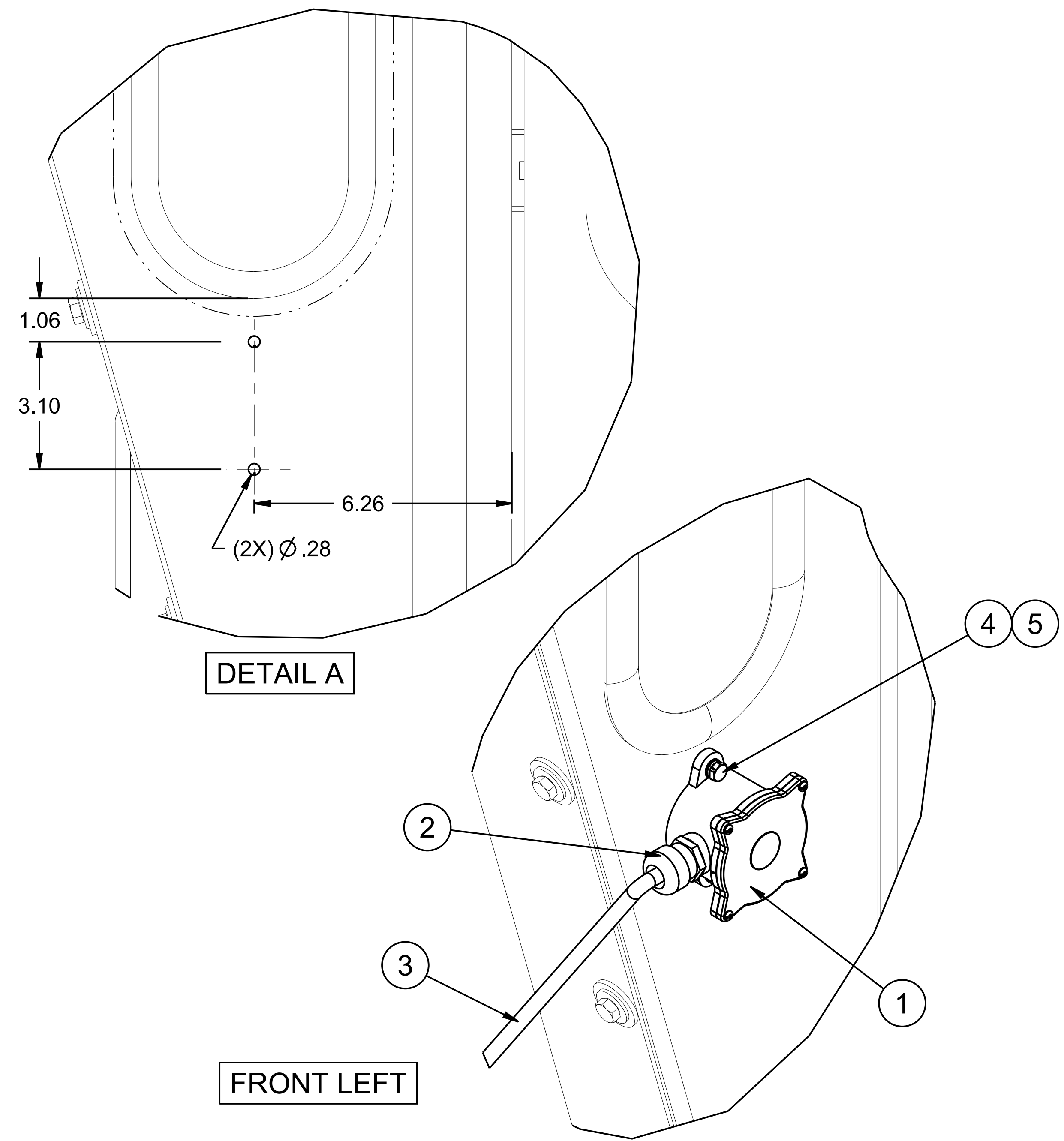

E51		STROBE ECCO (MACH. WITH AIR COND.)		
ITEM NO.	PART NUMBER OR MATERIAL	QTY. REQ.	PART NAME	NORDCO DWG.
1	5190474	1	LIGHT,STROBE W/CONNECTOR AMBER	
2	21383306	1	BRACKET,STROBE LIGHT 9" TALL	
3	2774771	2	CPSCR HX .375X.75	
4	3064470	2	WASHER LOCK .375	

CUSTOMARY: ALL DIMENSIONS IN INCHES					
IMPLIED TOLERANCES		PRODUCT: MODELS C & CX			
FRACTION	± 1/8	DESCRIPTION: SPECIFICATION, CX-BASED CAB			
X	± .06	SIZE	SCALE	DRAWING CODE NUMBER	REV.
XX	± .03	D	1/8	22224100	-
XXX	± .010	ASSEMBLY:-		SHEET 14 OF 21	
MACHINE FINISH UNLESS OTHERWISE STATED		PLANE ANGLES 90°-1°			

REVISION HISTORY LOCATED ON LAST SHEET

E54		STROBE SPEAKER LED		
ITEM NO.	PART NUMBER OR MATERIAL	QTY. REQ.	PART NAME	NORDCO DWG.
1	5190502	1	LIGHT,STROBE LED,AMBER 12-80V	
2	2837631	4	MACH SCR #10-24 X .750	
3	3060458	4	WASHER SAE .188 (#10)	
4	3042011	4	LOCNUT HEX #10-24	
5	21383311	1	BRACKET,STROBE LIGHT 9" TALL	Y
6	2774771	2	CPSCR HX .375X.75	
7	3064470	2	WASHER LOCK .375	

SPEAKER LED STROBE, TO BE INSTALLED AND CONNECTED TO CAB HARNESS

**WIRING INSTRUCTIONS:**

PACKARD CONNECTOR INFO:  
 PIN A - RED WIRE - POWER  
 PIN B - BLACK WIRE - GROUND  
 YELLOW WIRE - MODE CHANGE

MOMENTARILY CONNECT YELLOW WIRE TO POWER TO CHANGE MODE.

SET AT ROTATING BEACON MODE.

COVER END IN SHRINK WRAP AND HIDE IN WIRE LOOM

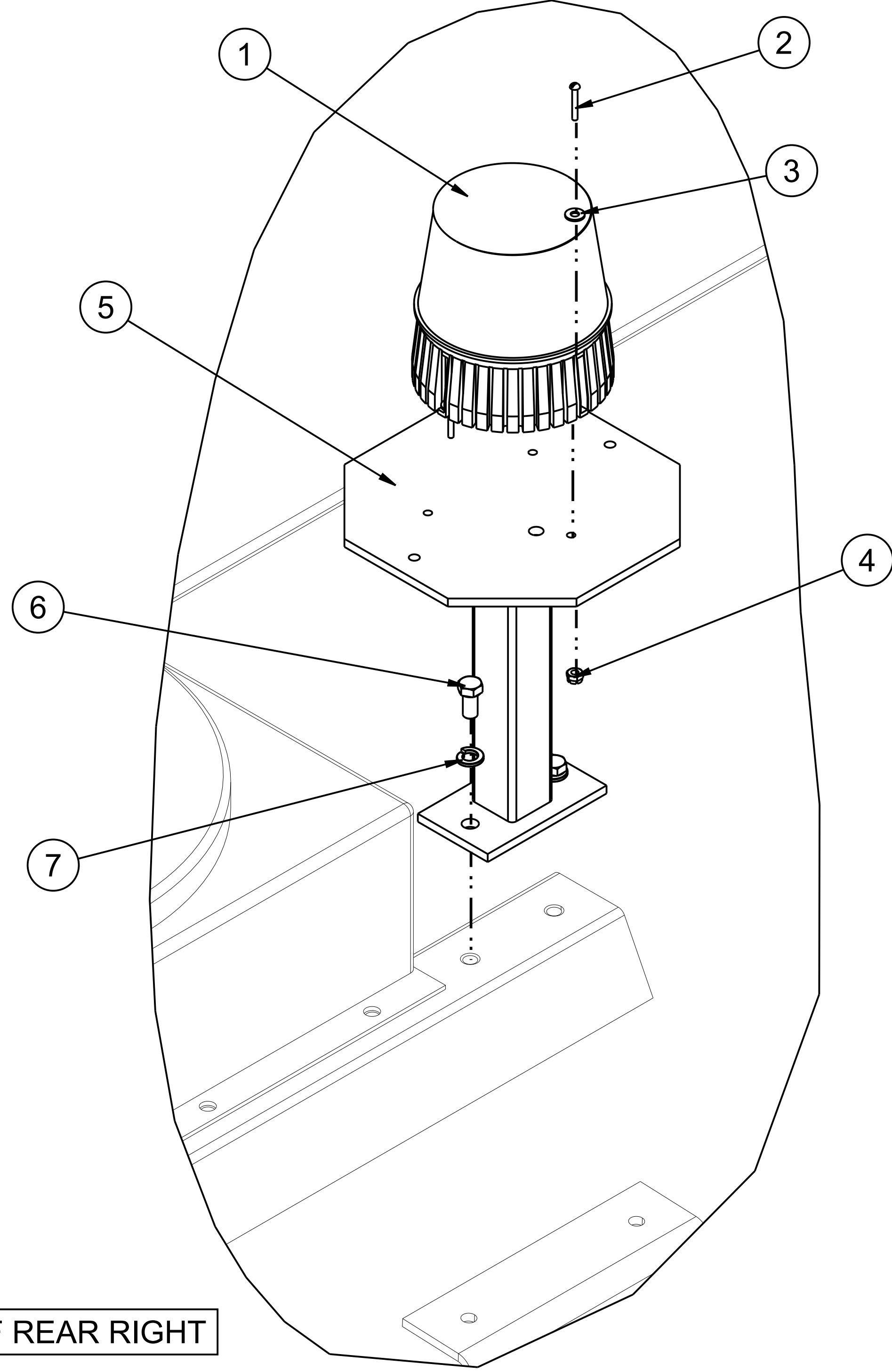

ROOF REAR RIGHT

E55		STROBE DOUBLE/QUAD FLASH		
ITEM NO.	PART NUMBER OR MATERIAL	QTY. REQ.	PART NAME	NORDCO DWG.
1	5190021	1	STROBE LIGHT,DOUBLE/QUAD FLASH	
2	21000485	1	BRACKET,STROBE LIGHT (FOLD DOWN)	Y
3	2774311	2	CPSCR HX .25X1.75	
4	3060025	2	WASHER WRT .250	
5	3064464	2	WASHER LOCK .250	
6	3001011	2	NUT HEX .250-20	
7	21383307	1	BRACKET,FLIP DOWN STROBE LIGHT	Y
8	2774771	2	CPSCR HX .375X.75	
9	3064470	2	WASHER LOCK .375	

STROBE: DOUBLE/QUAD FLASH, TO BE INSTALLED AND CONNECTED TO CAB HARNESS

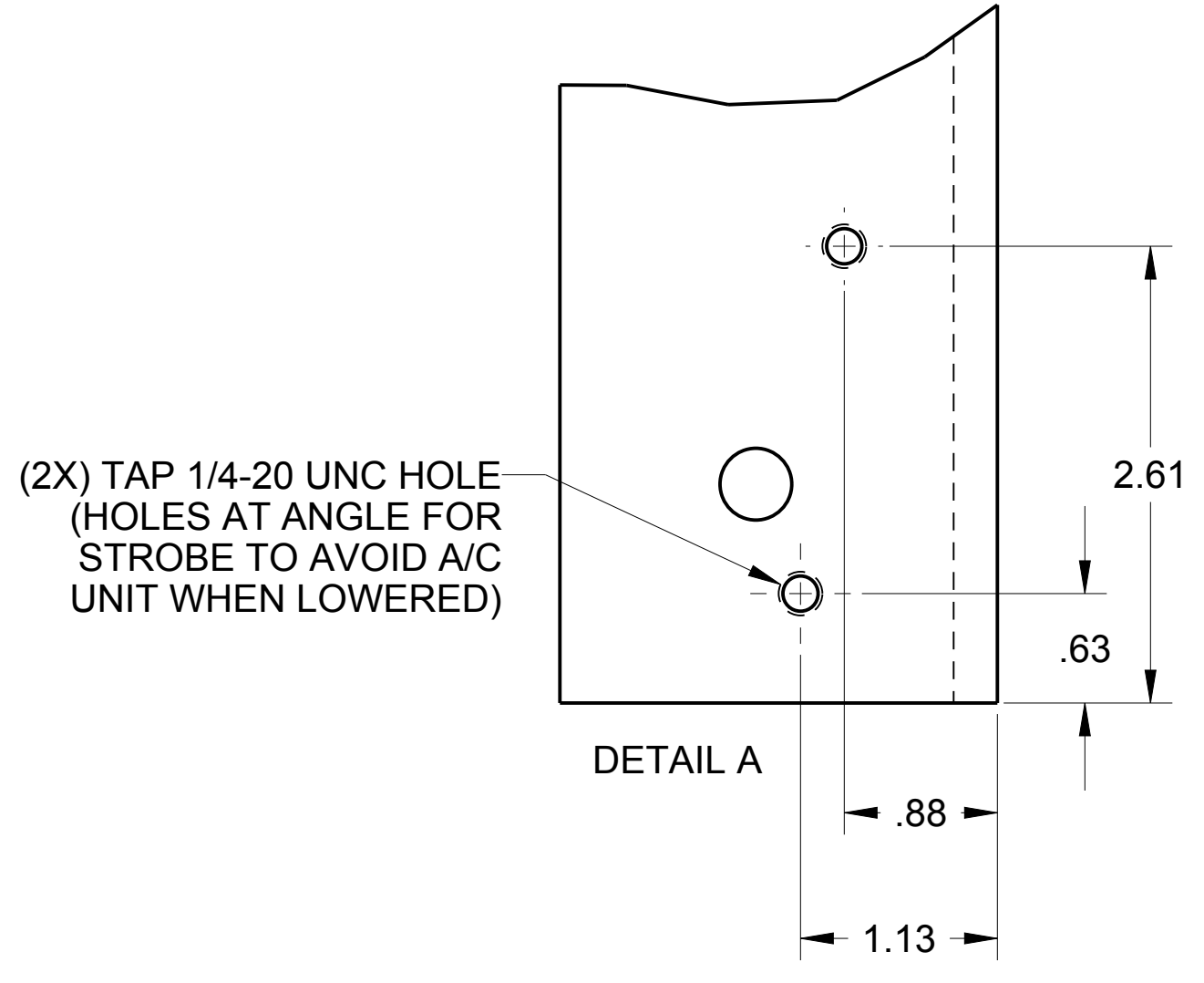

**STROBE: DOUBLE/QUAD FLASH INSTRUCTIONS:**

1. ATTACH PLASTIC STROBE BASE TO METAL STAND.
2. APPLY RTV SILICONE AROUND O.D. LIP OF STROBE BASE.
3. INSERT CABLE THROUGH POST OF METAL STAND.
4. SEAT STROBE ONTO PLASTIC SILICONE/BASE & SECURE WITH (4) SCREWS PROVIDED.
5. WIPE OFF EXCESS RTV.
6. ATTACH PIVOT BRACKET TO METAL STAND.
7. INSTALL STROBE LIGHT ASSY & INSERT LOOSE CABLE END THROUGH 1" GROMMET ABOVE REAR TRAVEL LIGHT.
8. ATTACH PACKARD (2-WAY SHROUD, MALE PINS) TO CABLE END. (WIRE COLORS TO MATCH ON MATING PACKARDS)
9. CONNECT MATING PACKARDS (BEHIND RH REAR TRAVEL LIGHT).
10. SECURE CABLE TO ROOF W/STUD GUN & CABLE CLAMPS.

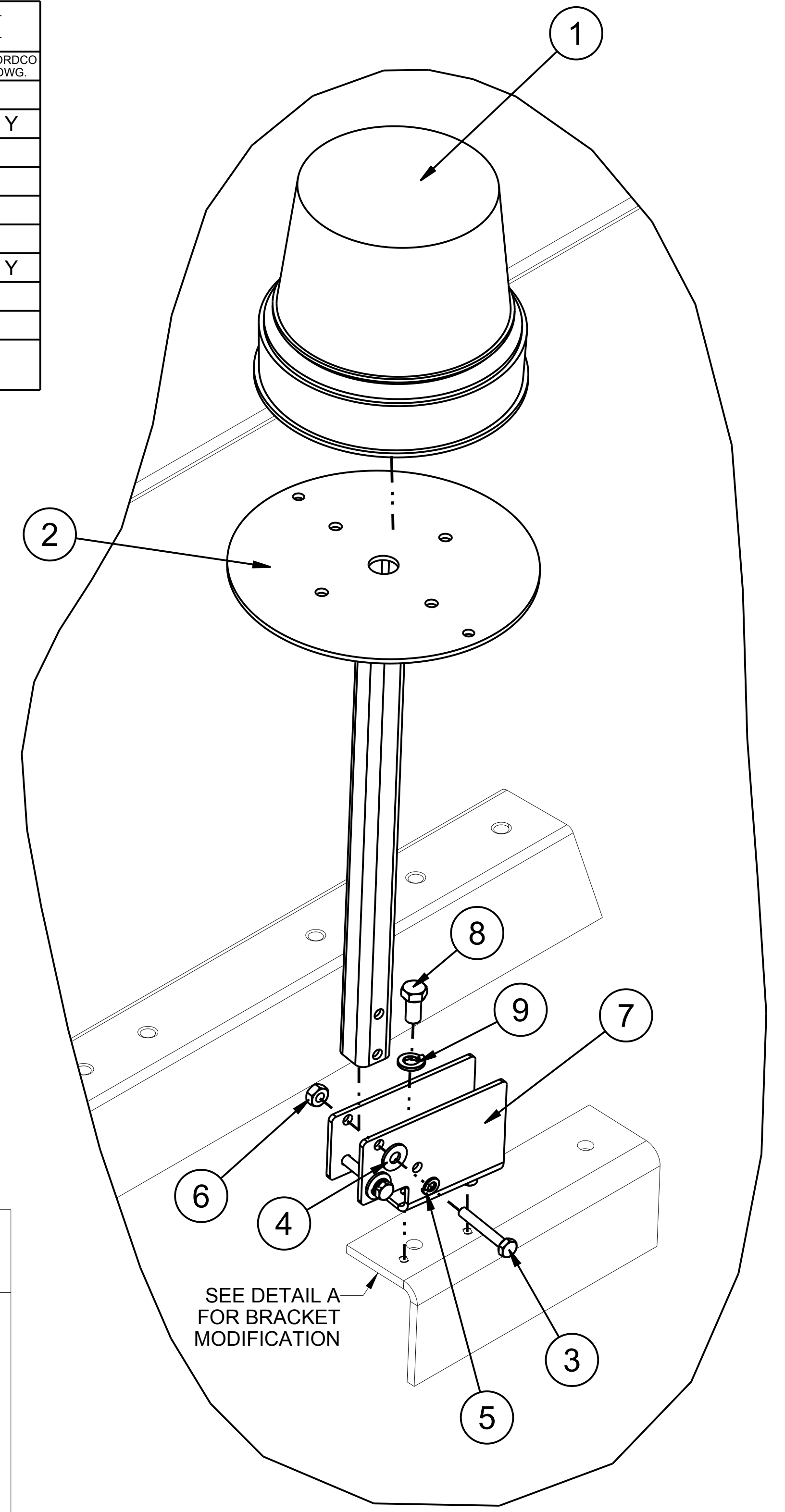

ROOF REAR RIGHT

CUSTOMARY: ALL DIMENSIONS IN INCHES				THIRD ANGLE PROJECTION	
IMPLIED TOLERANCES		PRODUCT: MODELS C & CX			
FRACTION	± 1/8	DESCRIPTION: SPECIFICATION, CX-BASED CAB			
X	± .06	SIZE	SCALE	DRAWING CODE NUMBER	REV.
XX	± .03	D	1/8	22224100	-
XXX	± .010	ASSEMBLY:-		SHEET 15	OF 21
MACHINE FINISH UNLESS OTHERWISE STATED					
PLANE ANGLES °-F'					

REVISION HISTORY LOCATED ON LAST SHEET

**M01** AIR CONDITIONING NOT REQUIRED

ITEM NO.	PART NUMBER OR MATERIAL	QTY. REQ.	PART NAME	NORDCO DWG.

**M03** AIR CONDITIONING VISIONAIRE

ITEM NO.	PART NUMBER OR MATERIAL	QTY. REQ.	PART NAME	NORDCO DWG.

FUTURE

**M02** AIR CONDITIONING RED DOT

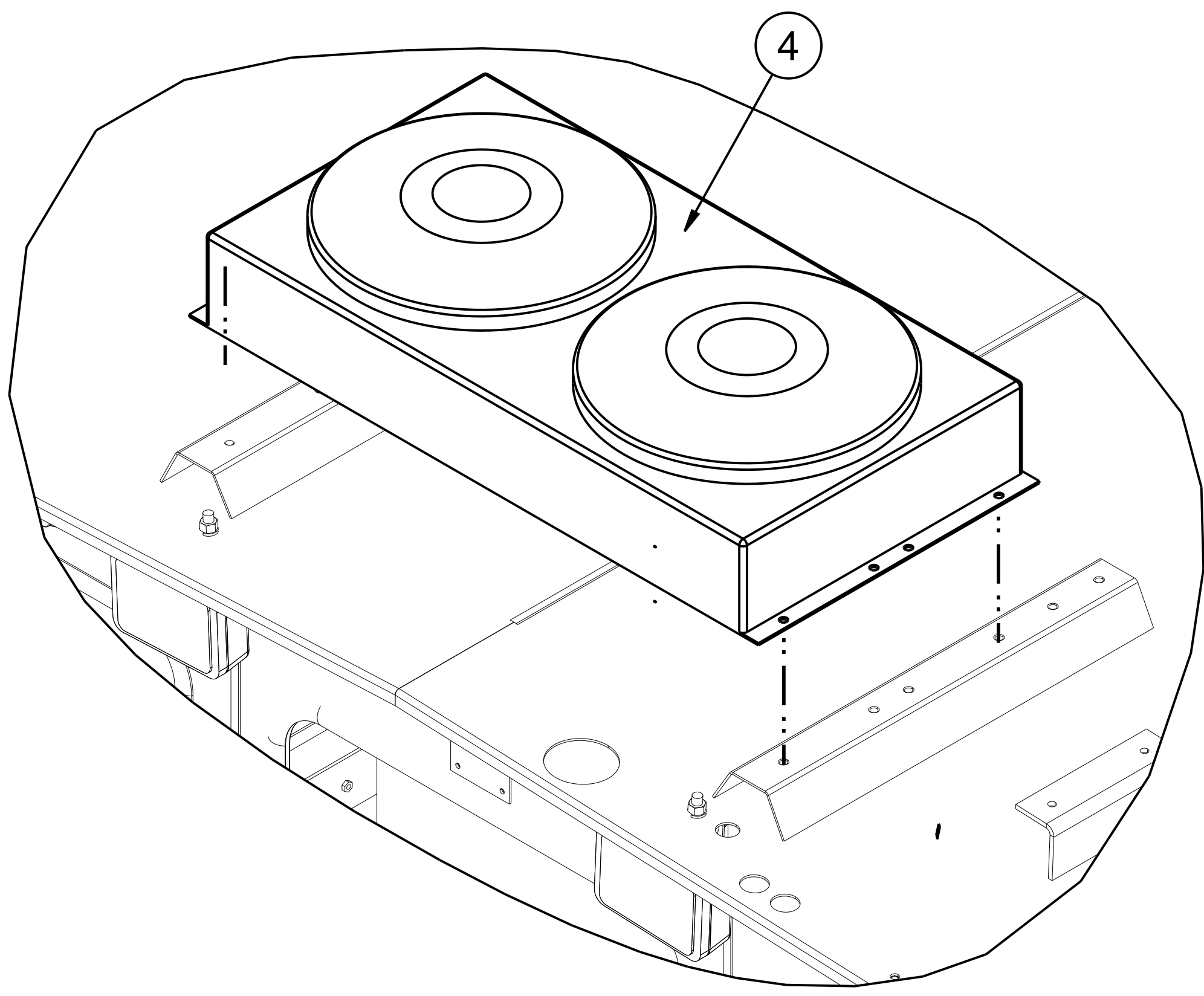

ITEM NO.	PART NUMBER OR MATERIAL	QTY. REQ.	PART NAME	NORDCO DWG.
1	96412408		AIR CONDITIONING RED DOT	
1	25730003		AIR CONDITIONER, RED DOT R-9715-3-24 HEADLINER	
2	61200152		RESISTOR, FAN SPD BADGER 71R1450	
3	640224		FILTER, AIR RD-1-08-60-0	
4	25730004		AIR CONDITIONER, CONDENSER RTOP BADGER-AIRE B-734-24	
4.1	10289915		DRIER, R-74-2546	
4.2	22239910		COIL, COND, BA7-2000	
4.3	22239911		PULLER FANS, RD-5-8785-3	
4.4	22239912		HOUSING, BA734958	
4.5	44253476		HOSE, BA-734-H1	

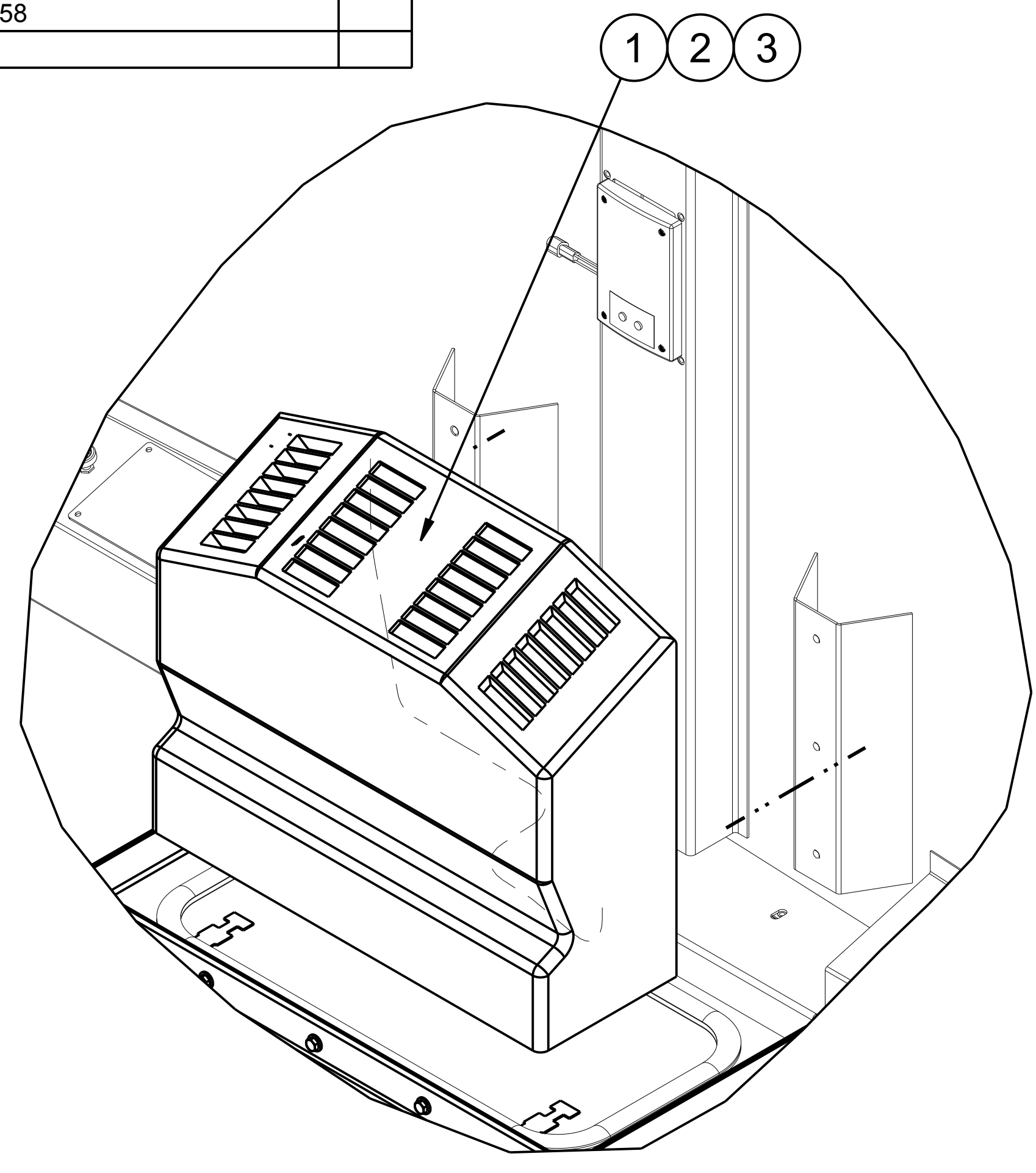

EXTERIOR-ROOF REAR



INTERIOR-CEILING REAR

CUSTOMARY: ALL DIMENSIONS IN INCHES		 PRODUCT: MODELS C & CX		 THIRD ANGLE PROJECTION	
IMPLIED TOLERANCES		DESCRIPTION: SPECIFICATION, CX-BASED CAB			
FRACTION	± 1/8	SIZE	SCALE	DRAWING CODE NUMBER	REV.
X	± .06	D	1/8	22224100	-
XX	± .03	ASSEMBLY:-			
.XXX	± .010	SHEET 16 OF 21			
MACHINE FINISH UNLESS OTHERWISE STATED		PLANE ANGLES 90°-1°			

REVISION HISTORY LOCATED ON LAST SHEET



M06		CAB PRESSURIZER		
ITEM NO.	PART NUMBER OR MATERIAL	QTY. REQ.	PART NAME	NORDCO DWG.
-	96411196	1	ASSY,CAB PRESSURIZER CX 24V	
1	96412754	1	ASSY, AIR PRESSURIZER	
1.1	32131050	1	AIR CLEANER	
1.2	18882465	1	BLOWER,PRESSURIZER 24V	
1.3	3049440	1	INDICATOR,DIFFERENCE AIR PRESS	
1.4	4599500	1	HOSE,.25 PLASTIC X 18.0 LONG	
1.5	1520725	1	COUPLING,PIPE .12	
1.6	2076100	1	ADAPTER,.12 MP X .25 PLAS TUBE	
1.7	4599501	1	HOSE,DUCT 3.00 W.B.X 45.0" LONG	
1.8	55490100	1	ADAPTER PLATE,3" HOSE	
1.9	24540596	2	CLAMP,HOSE 2.81-3.75 WM DRIVE	
1.10	77760010	2	SUPPORT FILTER MOUNTING BAND	
1.11	43971000	1	HOOD,INLET 4.5 OD DIA.	
1.12	0658100	1 FT	TRIM,VINYL EDGING,1/32-1/8 THK	
MOUNTING & HARDWARE				
2	21462410	1	BRACKET, MOUNTING	Y
3	2774781	4	CPSCR HX .375X1	
4	2774791	4	CPSCR HX .375X1.25	
5	3060031	8	WASHER WRT .375	
6	3064470	8	WASHER LOCK .375	
7	3001021	8	NUT HEX .375-16	

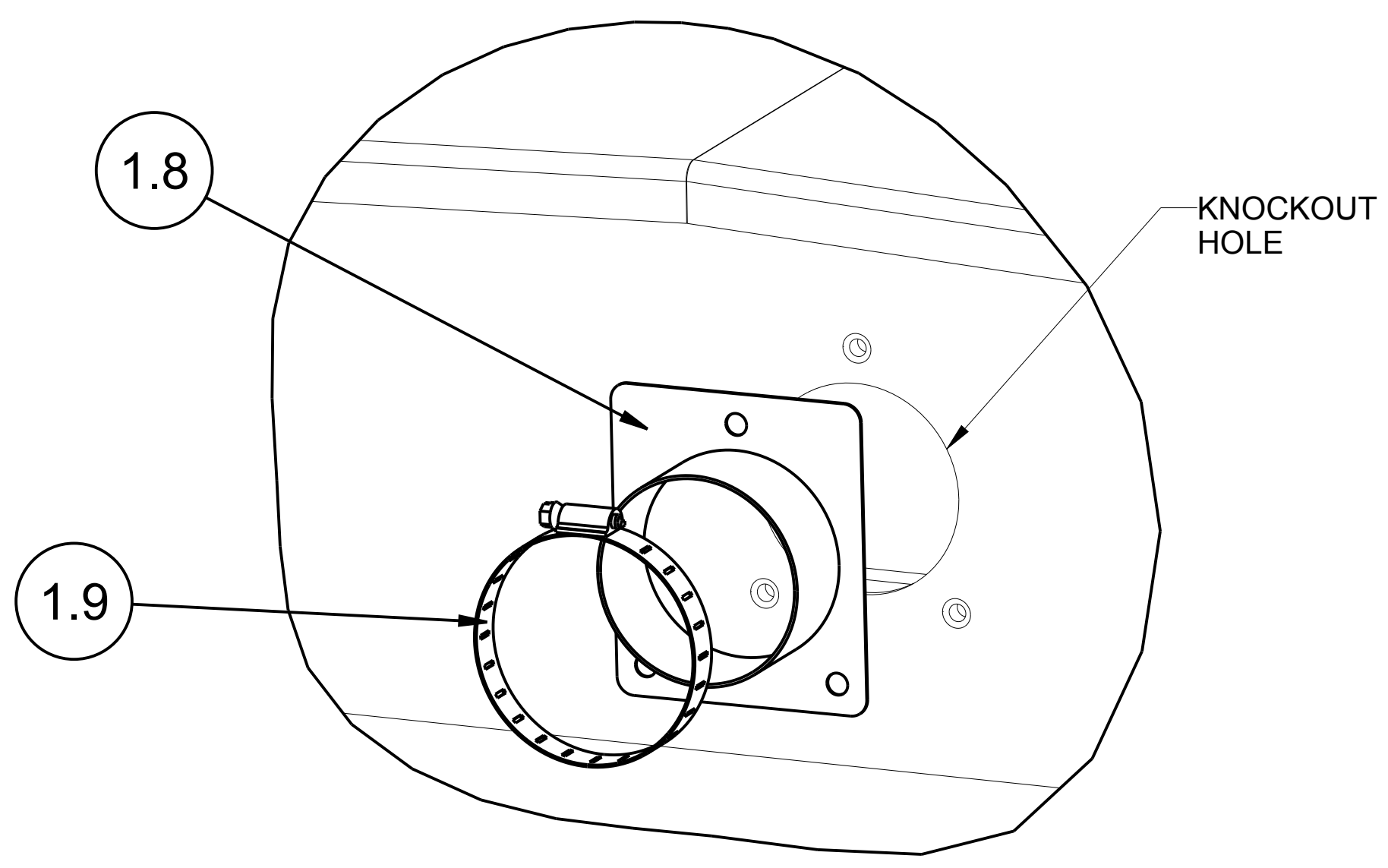

REAR CENTER PANEL

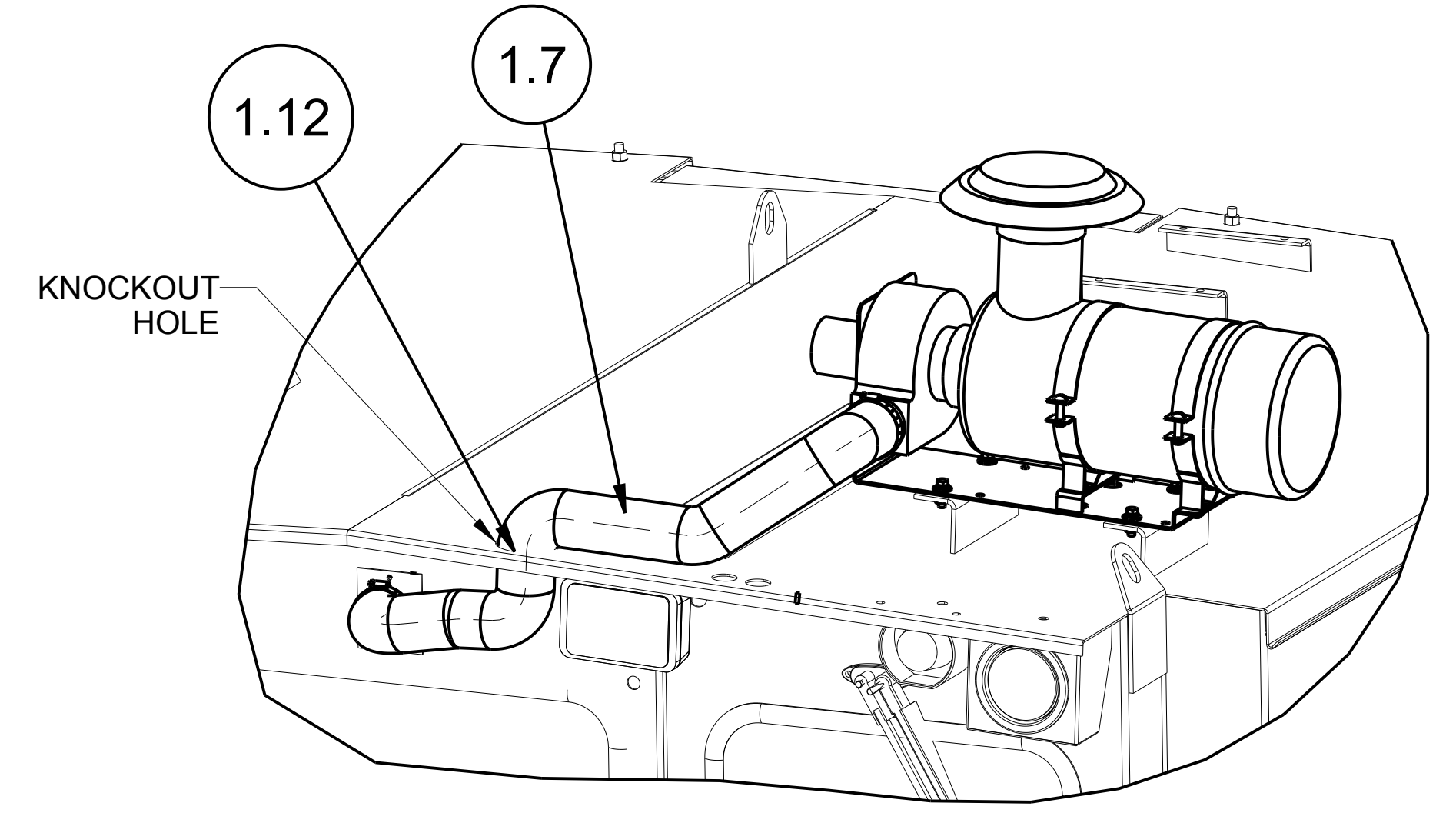

EXTERIOR-ROOF REAR

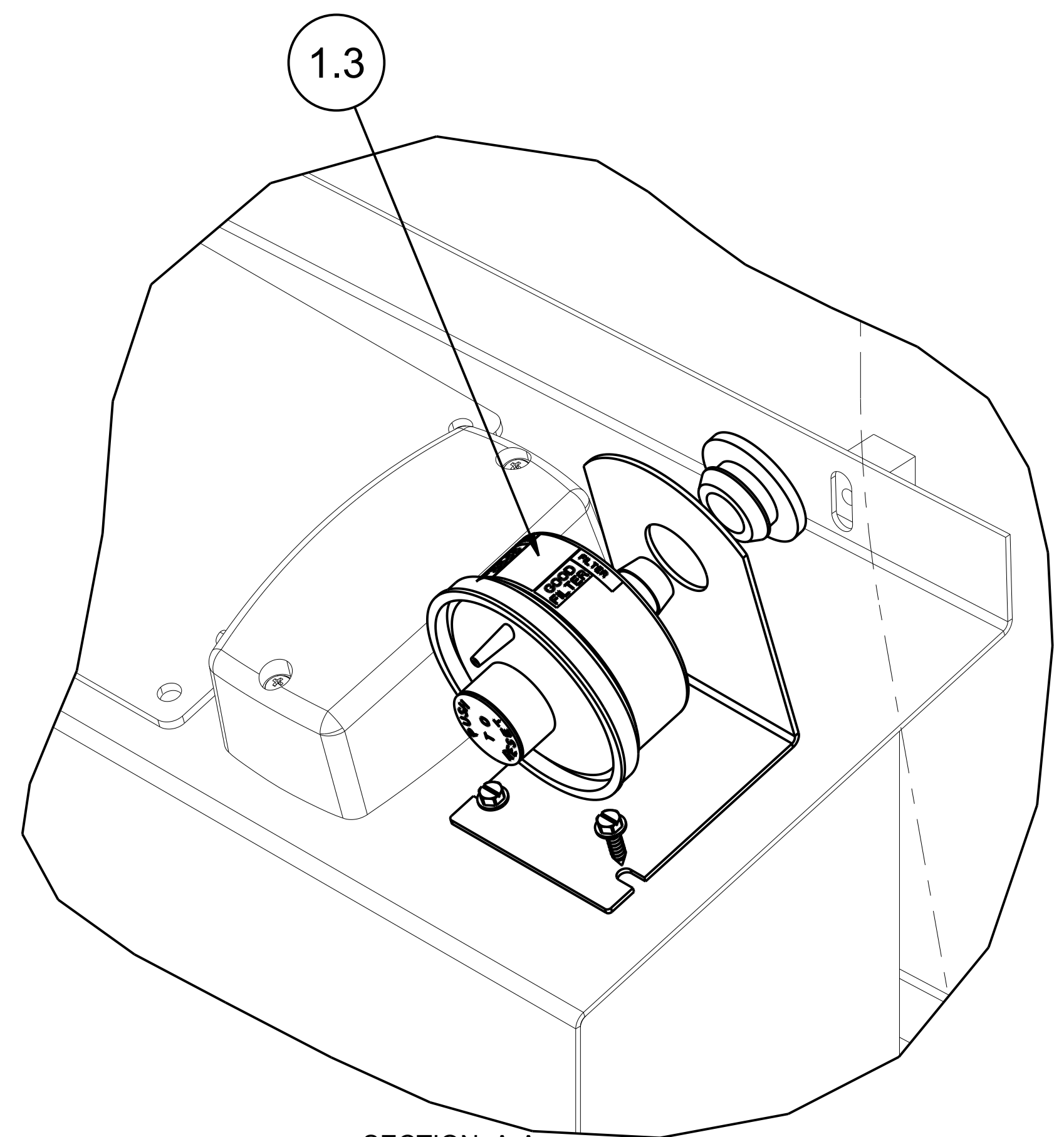

SECTION A-A  
SCALE 3/4

INTERIOR-CEILING  
REAR RIGHT PANEL

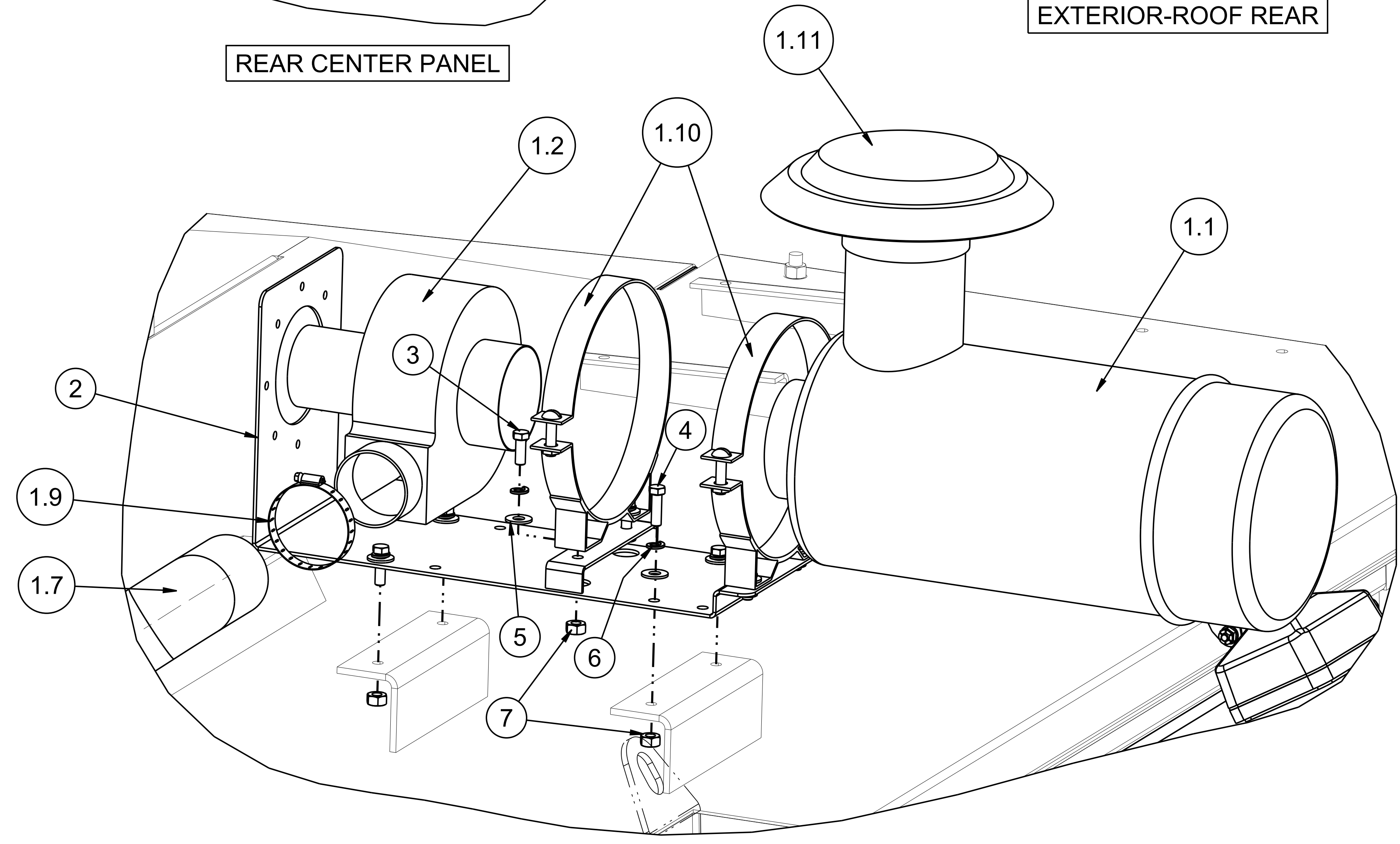

EXTERIOR-ROOF REAR

CUSTOMARY:					
ALL DIMENSIONS IN INCHES		PRODUCT: MODELS C & CX			
IMPLIED TOLERANCES		DESCRIPTION: SPECIFICATION, CX-BASED CAB			
FRACTION	± 1/8	SIZE	SCALE	DRAWING CODE NUMBER	REV.
X	± .06	D	1/8	22224100	-
XX	± .03	ASSEMBLY:-			
XXX	± .010	SHEET 17 OF 21			
MACHINE FINISH UNLESS OTHERWISE STATED		PLANE ANGLES 90°-F°			

REVISION HISTORY  
LOCATED ON LAST SHEET

CAB OPTIONS		WEST COAST MIRRORS		
ITEM NO.	PART NUMBER OR MATERIAL	QTY. REQ.	PART NAME	NORDCO DWG.
<b>M10</b>		<b>STANDARD WITH INTEGRATED CONVEX</b>		
1	8099452	2	MIRROR, WEST COAST 6"X16" COMBO	
2	42018018	1	HANDLE, GRAB W/MIRROR MTGS R.H.	
3	42018019	1	HANDLE, GRAB W/MIRROR MTGS L.H.	
4	8099460	2	BRACKET, MIRROR	
<b>M11</b>		<b>HEATED WITH INTEGRATED CONVEX</b>		
1	8099470	2	MIRROR, HEATED WEST COAST 24V	
2	42018018	1	HANDLE, GRAB W/MIRROR MTGS R.H.	
3	42018019	1	HANDLE, GRAB W/MIRROR MTGS L.H.	
4	8099460	2	BRACKET, MIRROR	

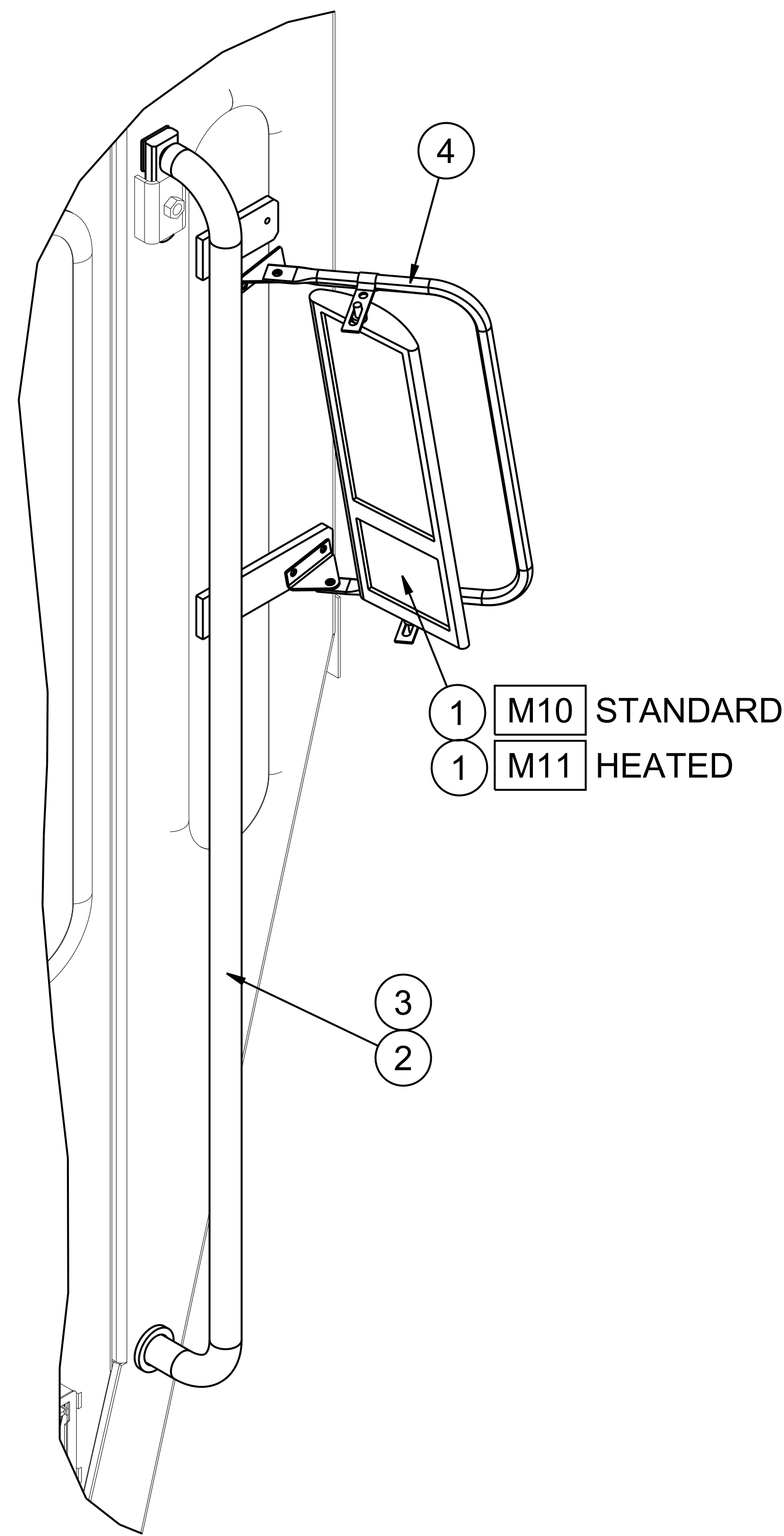

CAB EXTERIOR-RIGHT FRONT

CUSTOMARY: ALL DIMENSIONS IN INCHES					
IMPLIED TOLERANCES		PRODUCT: MODELS C & CX			
FRACTION	± 1/8	DESCRIPTION: SPECIFICATION, CX-BASED CAB			
X	± .06	SIZE	SCALE	DRAWING CODE NUMBER	REV.
XX	± .03	D	1/8	22224100	-
XXX	± .010	ASSEMBLY:-		SHEET 18 OF 21	
MACHINE FINISH UNLESS OTHERWISE STATED		PLANE ANGLES 90°-1°			

REVISION HISTORY LOCATED ON LAST SHEET

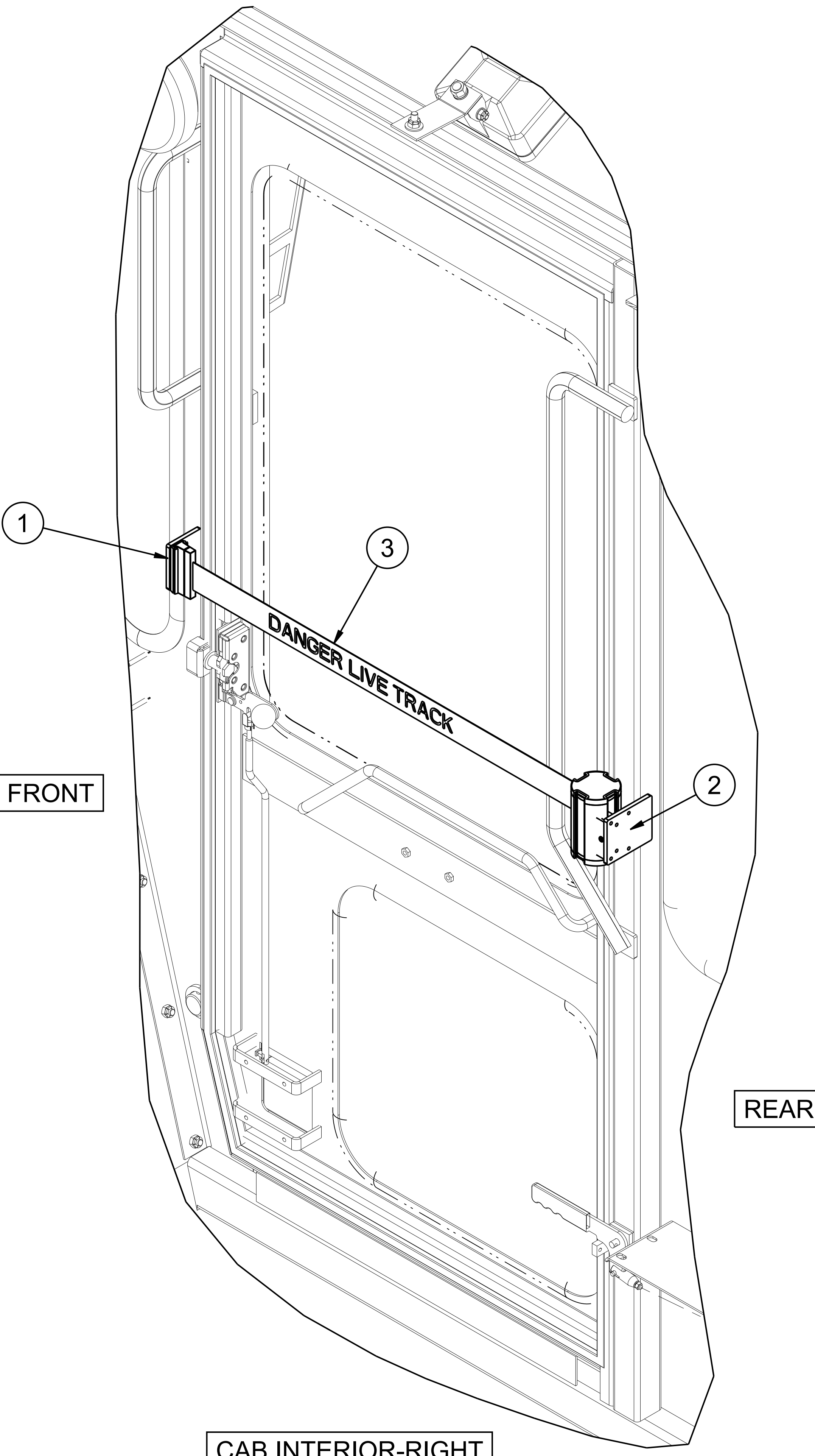
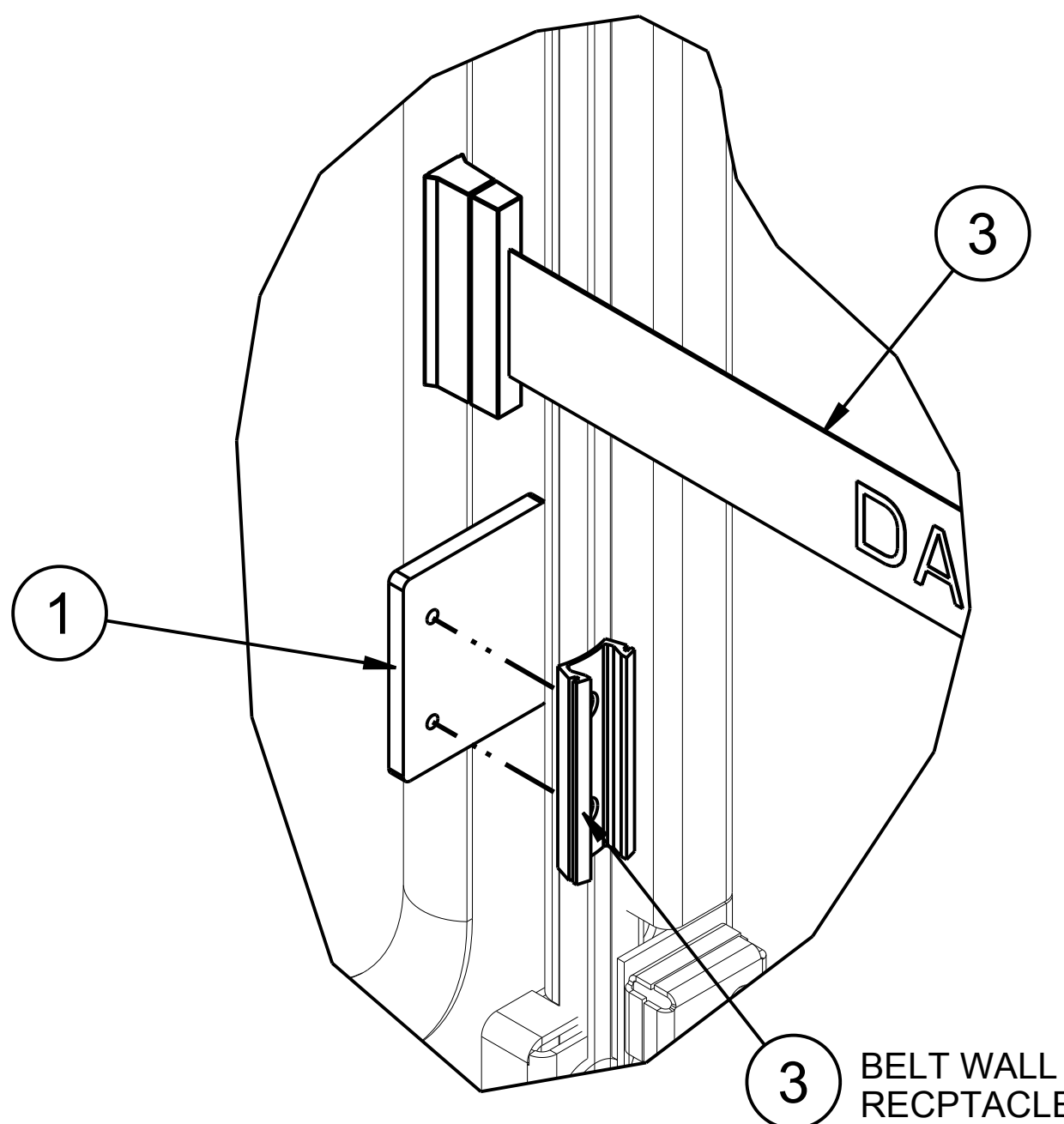

M12		LIVE TRACK RETRACTABLE BELT		
ITEM NO.	PART NUMBER OR MATERIAL	QTY. REQ.	PART NAME	NORDCO DWG.
1	56126535	2	PLATE,MTG FRONT,RCTBL LIVE TRK	Y
2	56126540	2	PLATE,MTG REAR,RCTBL LIVE TRK	Y
3	7550300	2	BELT,RETRACTABLE LIVE TRACK	

**LIVE TRACK: RETRACTABLE BELT INSTRUCTIONS:**

1. WELD 4-HOLE MTG PLATES TO CAB FRAME. (ON DOOR HINGE SIDE, 42" FROM FLOOR)
  2. WELD 2-HOLE MTG PLATES TO CAB FRAME. (ON DOOR LATCH SIDE, 43" FROM FLOOR)
- (AFTER PAINT)
3. MOUNT BELT WALL RECEPTACLE TO 2-HOLE WELDED PLATE.
  4. MOUNT CANISTER WALL PLATE TO 4-HOLE WELDED PLATE. (CENTER TAPPED HOLE AT BOTTOM)
  5. MOUNT CANISTER MECHANISM TO WALL PLATE & INSTALL LOCKING SCREW.
  6. ATTACH BOTTOM CAP TO CANISTER W/2 SCREWS PROVIDED.

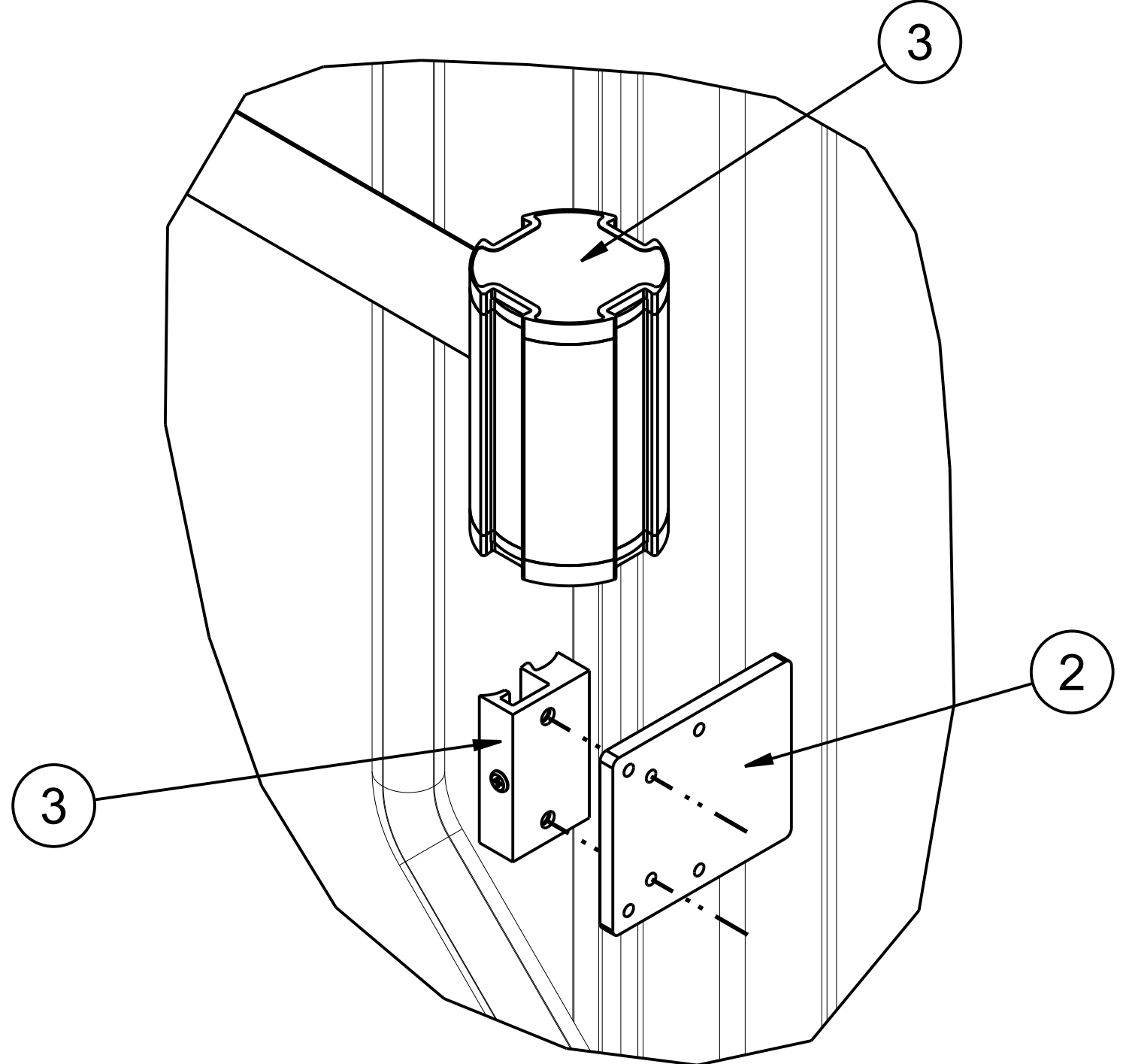

CUSTOMARY: ALL DIMENSIONS IN INCHES				THIRD ANGLE PROJECTION	
IMPLIED TOLERANCES		PRODUCT: MODELS C & CX			
FRACTION	± 1/8	DESCRIPTION: SPECIFICATION, CX-BASED CAB			
X	± .06	SIZE	SCALE	DRAWING CODE NUMBER	REV.
XX	± .03	D	1/8	22224100	-
XXX	± .010	ASSEMBLY:-		SHEET 19 OF 21	
MACHINE FINISH UNLESS OTHERWISE STATED		PLANE ANGLES 90°-F°			

REVISION HISTORY LOCATED ON LAST SHEET

CAB INTERIOR-RIGHT

**M14 CAB SUN SHADES**

ITEM NO.	PART NUMBER OR MATERIAL	QTY. REQ.	PART NAME	NORDCO DWG.
1	22233111	2	SHADE,SUN 22.00 X 50.00	
2	22233126	2	SHADE,SUN 27W X 50L GRAY GOLD	
3	22231026	2	RACE,SIDE DOOR (HINGE SIDE) 35" METAL FORMED ANGLE,3 HOLES	
4	44047911	4	HOOKS, OPEN .50 I.D. X 1.X 1.50L X .19WIR	
5	2837481	4	MACH SCR #8X.625	
6	3048034	4	NUT HEX. #8-32	

**M16 FRONT & FRONT SIDE WINDOWS STANDARD**

ITEM NO.	PART NUMBER OR MATERIAL	QTY. REQ.	PART NAME	NORDCO DWG.
1	87000005	2	PANE,SAFETY GLASS (28.75 X 28.25) GREY TINT	
2	87000013	2	PANE,SAFETY GLASS (37.25 X 5.25) GREY TINT	

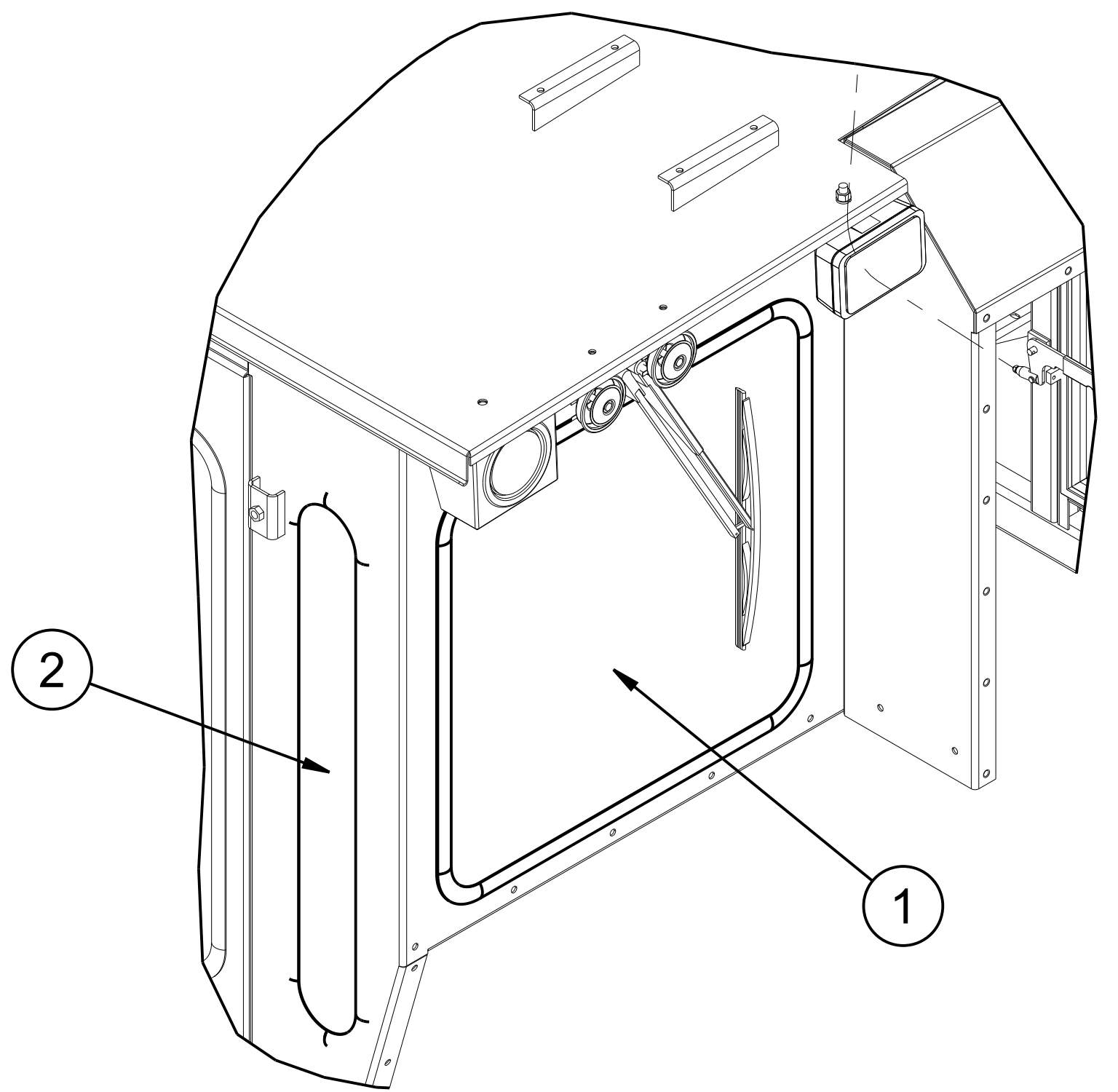

**M16 & M17 WINDSHIELD WIPERS**

M16				
ITEM NO.	PART NUMBER OR MATERIAL	QTY. REQ.	PART NAME	NORDCO DWG.
1	11050050	4	PANTOGRAPH ADAPTER KIT WWJ	
2	11050002	4	WIPER ARM,PANTOGRAPH 18"	
3	17760035	4	BLADE,WIPER 18"	
4	68582510	4	SHAFT,PIVOT WIPER MOTOR	
5	50211626	4	MOTOR,WIPER 24V	

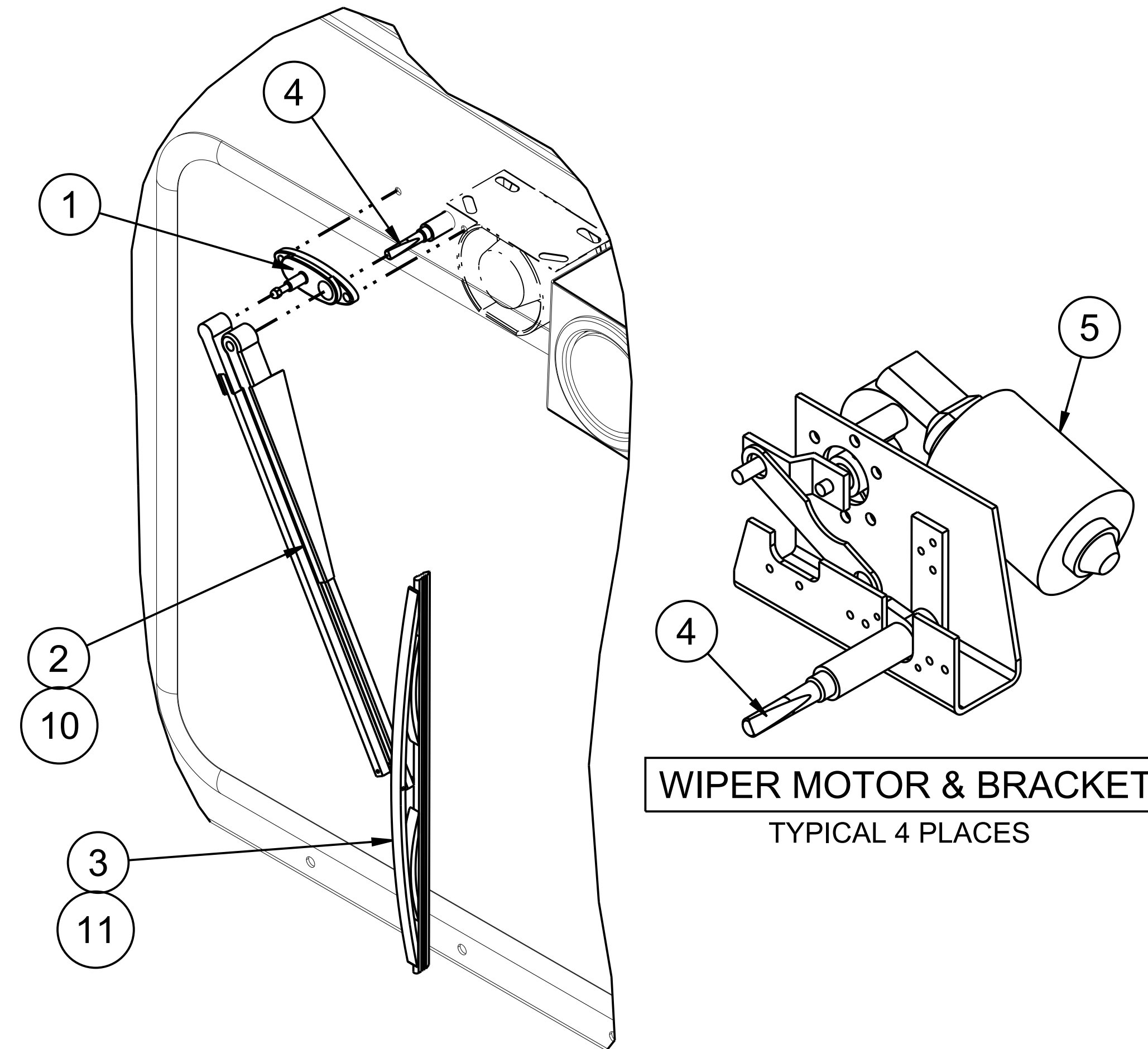

**WIPER MOTOR & BRACKET**  
TYPICAL 4 PLACES

M17				
ITEM NO.	PART NUMBER OR MATERIAL	QTY. REQ.	PART NAME	NORDCO DWG.
1	11050050	4	PANTOGRAPH ADAPTER KIT WWJ	
2	11050002	2	WIPER ARM,PANTOGRAPH 18" (REAR)	
3	17760035	2	BLADE,WIPER 18" (REAR)	
4	68582510	4	SHAFT,PIVOT WIPER MOTOR	
5	50211626	4	MOTOR,WIPER 24V	
10		2	WIPER ARM,PANTOGRAPH ??" (FRONT)	
11		2	BLADE,WIPER ??" (FRONT)	

**M15 WINDOW FILM TINT**

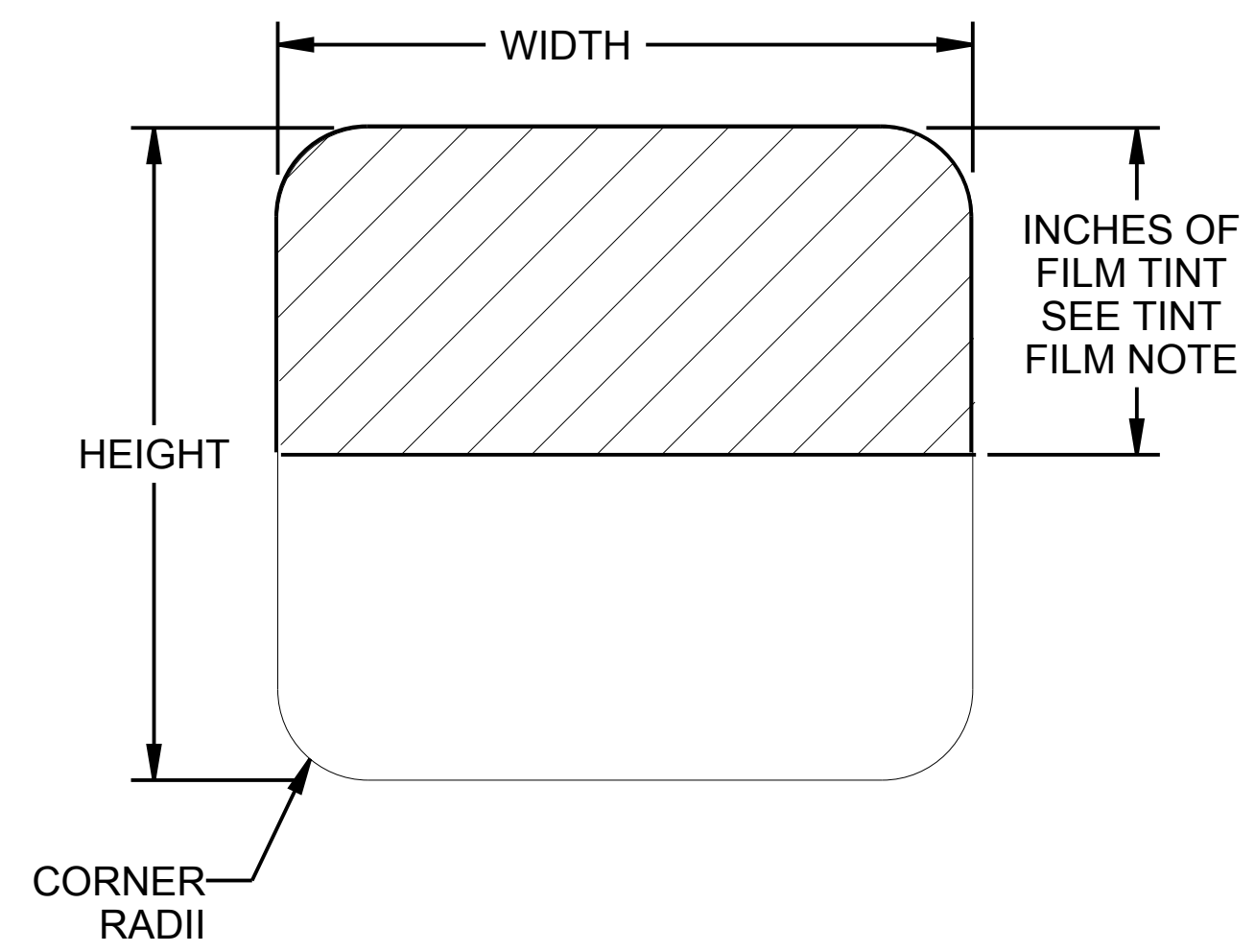

TINT FILM NOTE  
TO BE "INSTA-CLING" GREY, 20% VISIBLE TRANSMISSION. THE FILM TINT IS IN ADDITION TO TINT STATED IN MATERIAL NOTE.

SHAPE	HEIGHT (IN)	WIDTH (IN)	INCHES OF TINT FILM	NORDCO P/N
A	28.75	28.25	14	8370800

**M17 FRONT & FRONT SIDE WINDOWS SHORTENED**

ITEM NO.	PART NUMBER OR MATERIAL	QTY. REQ.	PART NAME	NORDCO DWG.
1	87000031	2	PANE,SAFETY GLASS (TBD X 28.25) GREY TINT	
2	87000033	2	PANE,SAFETY GLASS (TBD X 5.25) GREY TINT	

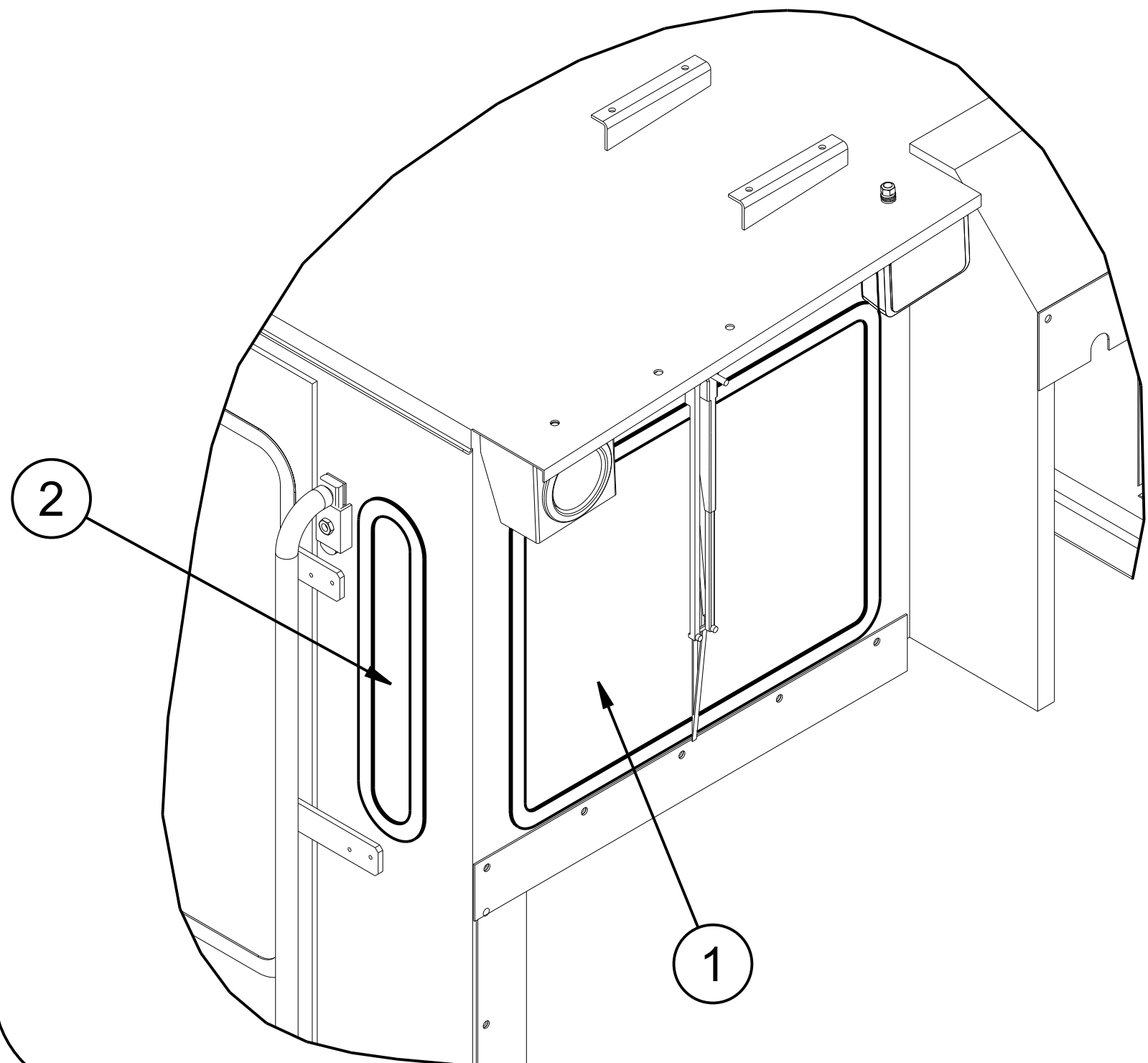

CUSTOMARY: ALL DIMENSIONS IN INCHES				THIRD ANGLE PROJECTION	
IMPLIED TOLERANCES		PRODUCT: MODELS C & CX			
FRACTION		DESCRIPTION: SPECIFICATION, CX-BASED CAB			
X	± .06	SIZE	SCALE	DRAWING CODE NUMBER	REV.
XX	± .03	D	1/8	22224100	-
XXX	± .010	PLANE ANGLES 45-90°		ASSEMBLY:-	SHEET 20 OF 21

REVISION HISTORY  
LOCATED ON LAST SHEET

ECO	600405	REV -
DRAWN BY:	CHECKED BY:	APPROVED BY:
SWA		
03-27-12		
SHEET	CHANGE	
ALL	NEW ISSUE	

**NORDCO ENGINEERING NOTES:**

1. WHEN REVISING THIS DRAWING, ALSO UPDATE BOM FOR P/N22224100.  
EXAMPLE: SEQUENCE NUMBER FOR E02, ITEM 6 TO BE 050206 (THE LETTER E=05, M=13, S=19, W=23).
2. WHEN ADDING A NEW CAB P/N TO THIS DRAWING, ATTACH 22224100 TO MULTIMEDIA, AND MAKE THE ONLY STRUCTURE UNDERNEATH P/N22224100.

CUSTOMARY:					
ALL DIMENSIONS IN INCHES		PRODUCT: MODELS C & CX			
IMPLIED TOLERANCES		DESCRIPTION: SPECIFICATION, CX-BASED CAB			
FRACTION	± 1/8	SIZE	SCALE	DRAWING CODE NUMBER	REV.
X	± .06	D	1/8	22224100	-
XX	± .03	ASSEMBLY:-			
XXX	± .010	SHEET 21 OF 21			
MACHINE FINISH UNLESS OTHERWISE STATED		PLANE ANGLES 90°-1°			

REVISION HISTORY LOCATED ON LAST SHEET

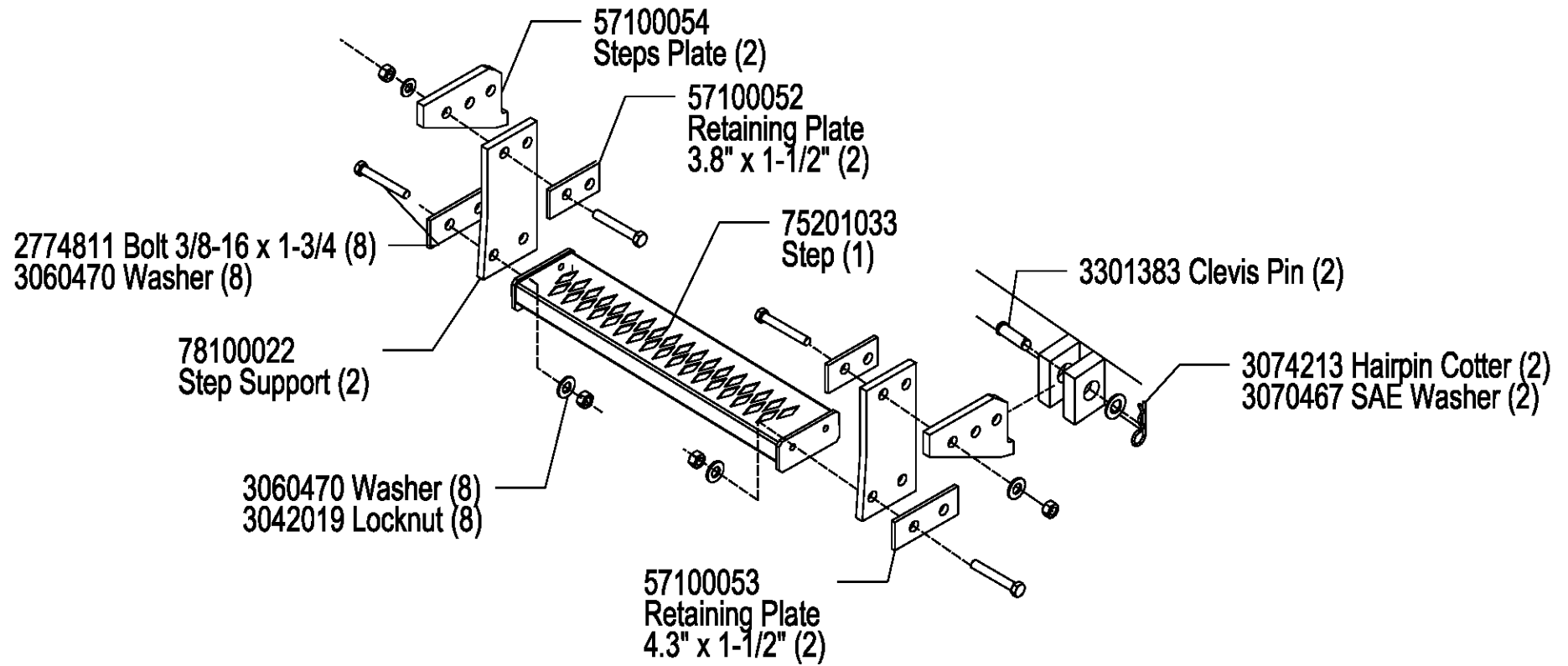

## FIGURE 25-7. CAB STRUCTURE Air Conditioning

